

VRF V^{PLUS}

100% INVERTER

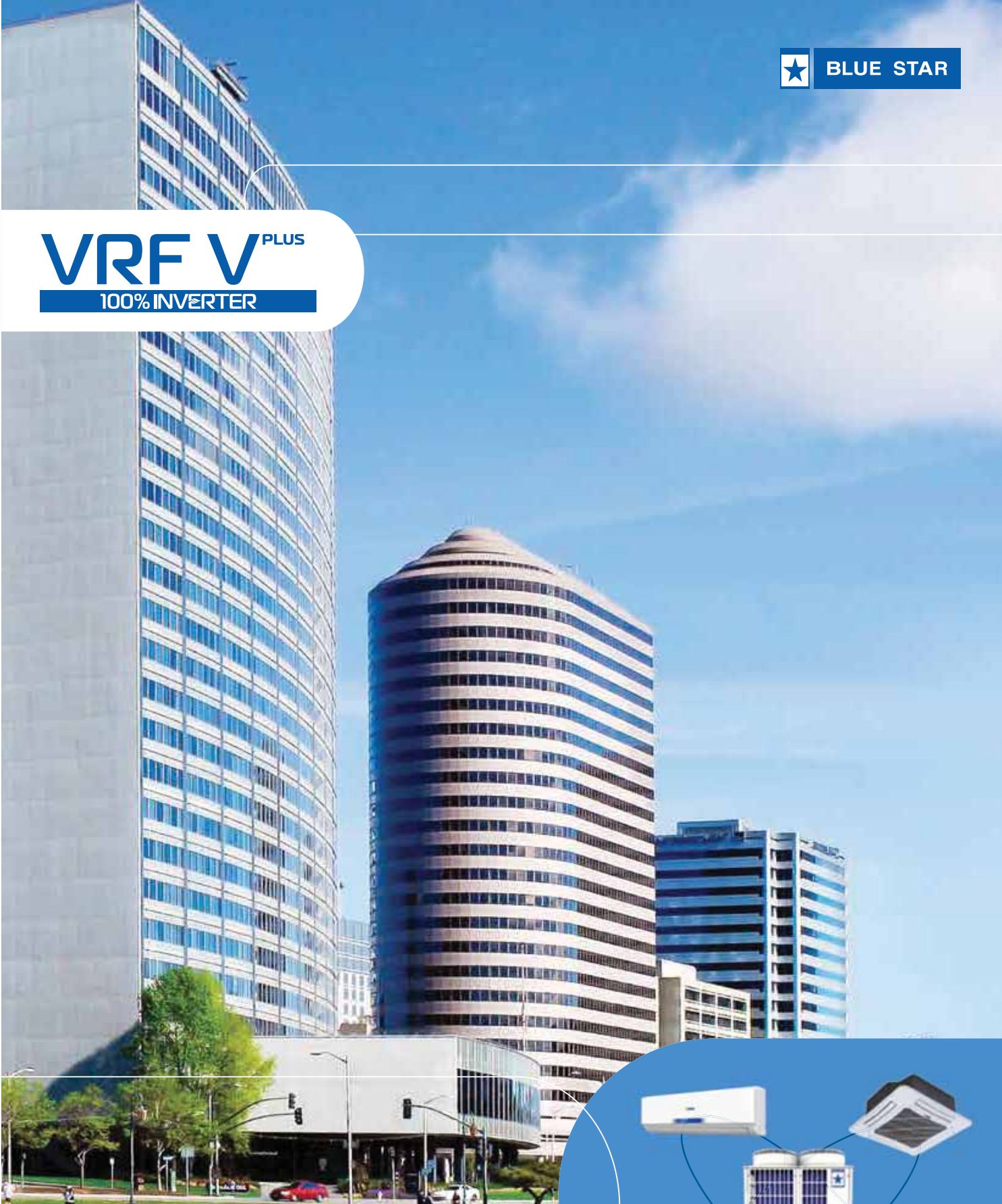

100% capacity at 43°C.
Non-stop cooling even at 56°C.





Blue Star is India's leading HVAC solutions provider. Our expertise in providing air conditioning solutions to diverse segments comes from our experience of over 7 decades in the industry.

Today, the Company is a market leader in almost every aspect of the cooling business – Room ACs, VRFs, Packaged and Ducted Splits and Chillers in the air conditioning space and Water Coolers, Deep Freezers and Cold Rooms amongst refrigeration and cooling products.

Apart from its wide range of products and solutions for which the Company offers technical and service support across the length and breadth of the country, Blue Star is also known for its commitment to technology. Over the decades, Blue Star has been the pioneer in introducing the latest technologies in the industry to the Indian market. We brought in the first scroll and then the tandem scroll packaged units to give our customers a heads-up in power savings. We developed the first high-performance packaged units that cool high sensible loads even at high ambients. We switched to eco-friendly refrigerants well ahead of others. We introduced Inverter technology in various product ranges. And we developed unique VRF solutions to suit the tropical climatic conditions of the Indian subcontinent.

Cutting-edge R&D

Blue Star's innovations are born at the high-end R&D establishment that has been painstakingly put together over decades, with the brightest brains and the latest equipment in place.

Recognised by the Department of Science and Industrial Research (DSIR) - Ministry of Science and Technology, Government of India, Blue Star's R&D wing has enabled the Company to file more than 25 patents and win many prestigious innovation awards.



CII Design Excellence Award 2017

Blue Star's R&D wing is equipped with advanced engineering design softwares such as Pro ENGINEER, Solid Edge, PRO-Mechanic, Rhino, Alias and ANSYS Fluent. There are also advanced software tools employed for system design, product performance rating, selection and heat exchanger optimisation.

World-class Testing Facilities

Blue Star's infrastructure for conducting various performance tests on new products is one of the largest in the country, ensuring that every product and technology is tested vigorously before being productionised.

The Company's chiller Testing Facility is AHRI-certified.



Products designed are also subject to various reliability tests before they are cleared for manufacturing. These include endurance, vibration and shock tests along with life-cycle and ageing tests to rigorously evaluate design reliability.

All Blue Star products are designed to perform in tropical weather conditions with high ambients, high humidity, under extreme voltage conditions and fluctuations. All designs are tested for performance under high ambient conditions and extreme power conditions as prevalent in India.

Advanced Psychrometric Test Lab at Dadra

Blue Star's Dadra factory has a modern Psychrometric Test Lab that can simulate and test VRFs under various conditions. All machines manufactured at the factory are rigorously tested for various parameters at this facility before despatch. Customers too can witness actual performance tests conducted on the new VRF V Plus before despatch of their machines, making Blue Star one of the few companies in the air conditioning industry offering this facility.



Psychrometric Test Lab



The Psychrometric Laboratory at the Dadra R&D Facility has been assessed and accredited in accordance with the Standard ISO/IEC 17025:2005 "General Requirements for the competence of Testing & Calibration Laboratories" by The National Accreditation Board for Testing and Calibration Laboratories (NABL)

The scope of accreditation includes international standards like ISO, EN, AHRI, UAE.S, SASO, GSO etc and Domestic Standard ISO.

These Laboratories are the first in the country to get NABL accreditation for Energy Rating Standards like SASO 2663, QS.SASA 2663, Bahrain Energy Rating, ESMA UAE.S 5010.1 and UAE.S 5010.5

World-class Manufacturing

Blue Star's manufacturing strength is spread across seven state-of-the-art manufacturing facilities across the country. The new Blue Star VRF V Plus units are manufactured at the contemporary and modern factory at Dadra. Set up to international standards, the products manufactured at this ISO 9001-2008 certified factory are not only sold across India but also exported to various countries across the globe too.

Dadra Factory



Panel Punching Machine



Ensuring an Excellent Finish

Blue Star's production facilities use raw materials that are of the highest quality, including corrosion resistant, galvanised steel for enhanced life and rust protection. The equipment used to process the steel include CNC machines such as the Amada Punch press, Hydraulic Press and specialised microprocessor-based protection and resistance welders. All these machines ensure superior quality in cabinet fabrication with tight tolerances.

All products are powder coated by specialised process equipment from Nordson of the USA on fully conveyerised lines. These equipments are fitted with electro-mechanical oscillators that ensure an even powder coating. A 'smart spray' mechanism senses movement of the conveyor and geometry of the component to adjust powder flow.





Paint Shop



Panel Bending Machine



Blue Star is equipped with a high-tech coil manufacturing setup using imported Burr Oak machines that can manufacture high-efficiency plain coils as well as enhanced split fins for superior heat transfer.

The copper tubes are then processed by a bank of PLC-controlled Burr Oak machines that ensure perfect bonding between the copper tubes and fins for superior performance. The coils are then tested for fine leaks with ultra-sensitive electronic leak detectors to enhance reliability.

VRF V Plus Advantage

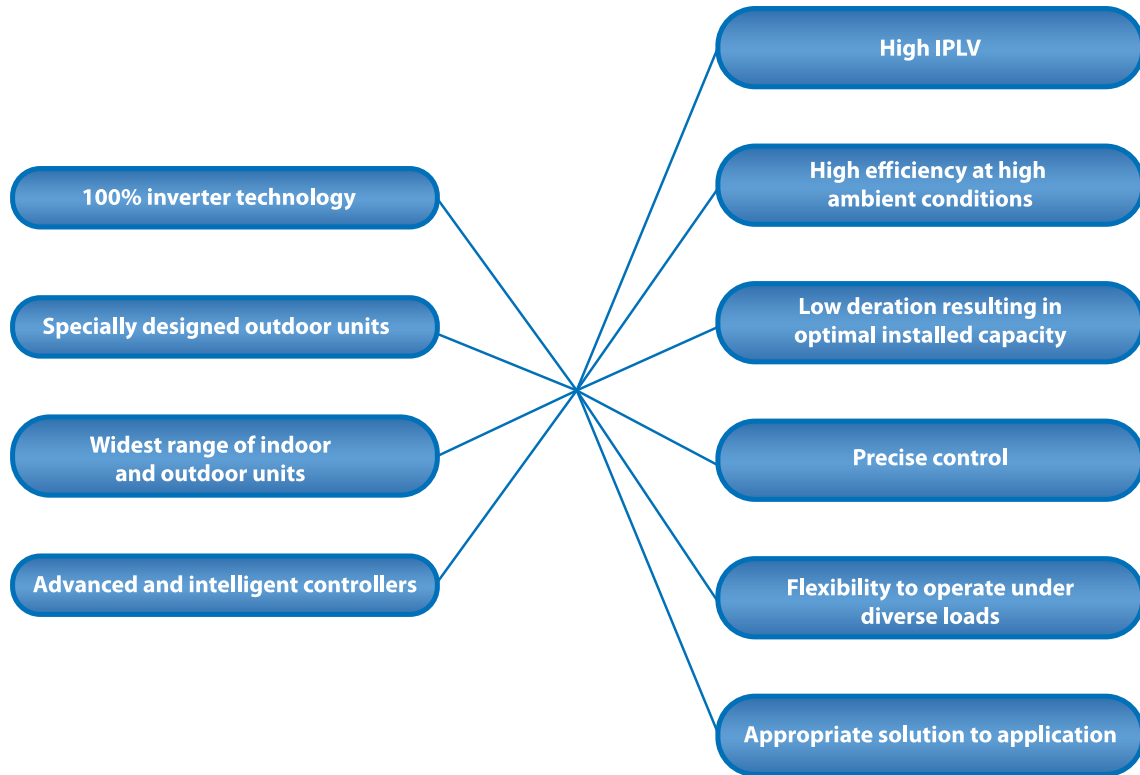



Hi-Wall Units



Four-Way Cassettes



Compact Cassettes



One-Way Cassettes



Two-Way Cassettes



Floor Cum Ceiling Mounted Units



Verticools



Concealed Splits



Ductable IDUs



Floor Mounted Packaged Units



Air Handling Units













Heat Recovery Ventilation System





Treated Fresh Air Unit

Product Line-up: Indoor Units

Appearance	Type	0.6TR	0.8TR	1TR	1.3TR	1.5TR	1.6TR	1.7TR	2TR	2.3TR	2.5TR	2.8TR	3TR	3.2TR	4TR	5TR	6TR	8TR	10TR
	Hi-Wall Units		●	●	●	●		●	●										
	Four-Way Cassettes			●	●	●		●	●	●		●		●	●	●			
	Compact Cassettes	●	●	●	●	●													
	One-Way Cassettes	●	●	●	●	●	●		●										
	Two-Way Cassettes	●	●	●	●	●		●	●										
	Floor Cum Ceiling Mounted Units					●			●				●		●	●			
	Verticools								●	●		●		●	●				
	Concealed Splits		●	●	●	●			●										
	Ductable IDUs					●			●		●		●		●	●	●	●	
	Floor Mounted Packaged Units															●		●	●

Add-ons







	Treated Fresh Air Unit	3.5 TR	5.5 TR	6.8 TR
---	------------------------	--------	--------	--------

	Heat Recovery Ventilation System	300 CMH	500 CMH	900 CMH
--	----------------------------------	---------	---------	---------

	AHU Kit	5 TR	6.5 TR	8 TR	10 TR	12.5 TR	15 TR	20 TR	25 TR	32 TR
---	---------	------	--------	------	-------	---------	-------	-------	-------	-------

	Ceiling Mounted Ductable IDUs AHU Type	11 TR	18 TR	20 TR
---	--	-------	-------	-------

	Floor Mounted Units AHU Type	18 TR	22 TR
--	------------------------------	-------	-------

Appearance	Type
	Cordless Remote Controller
	Wired Controller
	Group Controller
	Central Controller
	PC Monitoring System
	Keycard Controller
	Tenant Billing System
	BMS Compatibility
	Mobile App
	Remote Monitoring Service
	Data Concentrator

UNIQUE FEATURES OF THE VRF V PLUS

Highly Efficient Inverter Compressors

The unique design of the inverter compressor ensures that the refrigerant is directly injected into the compressor chamber. Since the suction gas enters directly into the scroll, there is no superheat gain due to the compressor motor assembly. This results in efficiency enhancement by up to 3%.



High pressure discharge chamber compressors

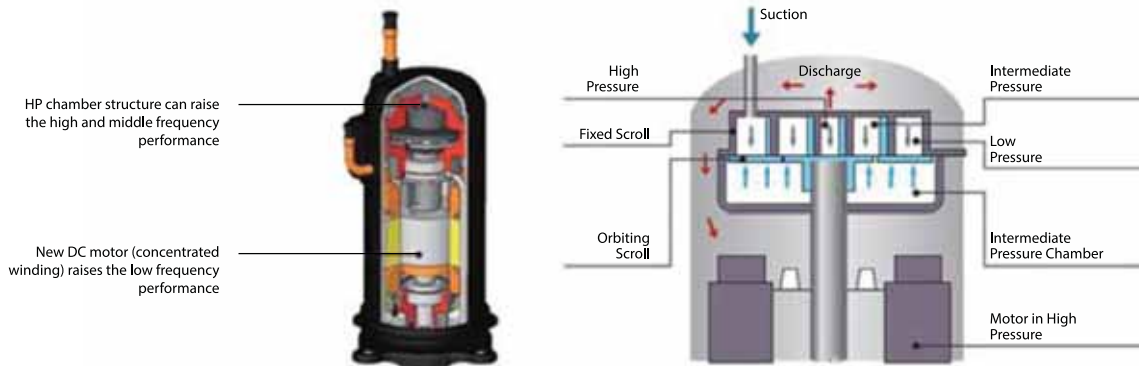

The speed of the conventional inverter compressors is, in general, restricted to 30% as lower speed may affect the flow of the lubricating oil in the compressor. However, the unique inverter compressor used in Blue Star's VRF V Plus uses a high pressure discharge chamber design which ensures uniform oil flow irrespective of the speed of the compressor, giving the system the flexibility to operate under extremely low loads (even below 30%), which is not possible with other compressors.

When the hot gas from the scroll is discharged into the high pressure chamber, the velocity is reduced. Hence, the whole design acts like a muffler and reduces noise levels to a great extent.

The compressors are also fitted with concentrated windings which reduce slip loss of motors when operating at low speeds. This results in enhanced efficiency compared to other windings by up to 7% on part loads.

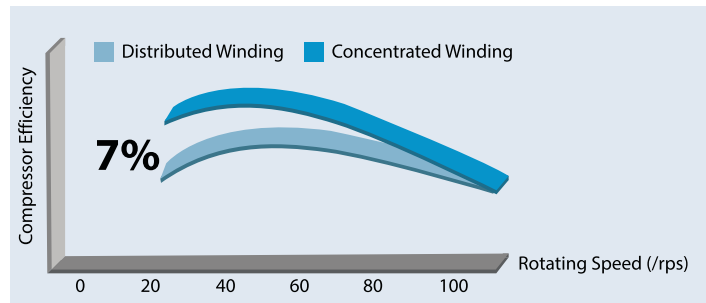

Not just that, powerful, permanent rare-earth magnets are used in the rotors of the DC inverter compressors. This allows the stators to be designed smaller which ultimately results in low power consumption.

Blue Star's 100% Inverter Advantages

Blue Star's VRF V Plus units are fitted with 100% inverter compressors. The unique logic of the system is that it optimally loads compressors in such a way that maximum efficiencies are achieved under any load condition.

Normal VRF at 50% Load

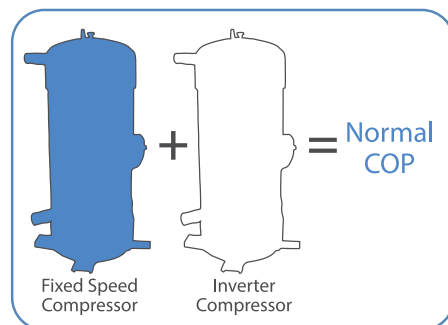

VRF V Plus at 50% Load

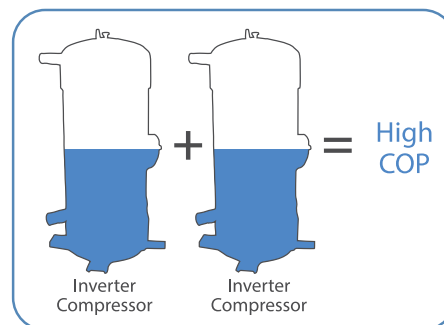

The other advantage of 100% inverter systems is the low starting current compared to VRF systems fitted with fixed and variable capacity compressors. This helps optimise electrical requirements, like generator capacity and cable sizes.

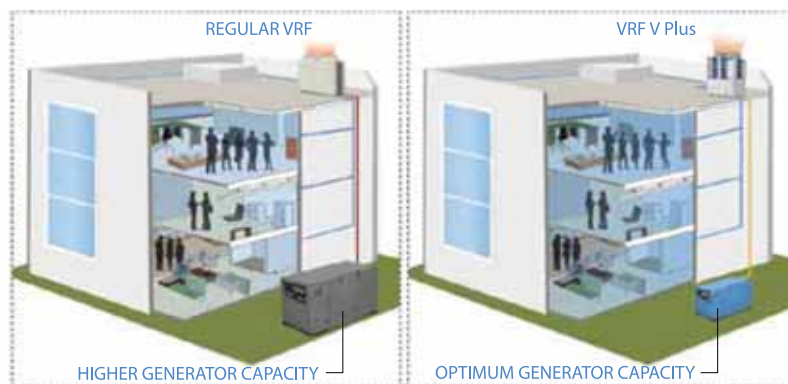

Specially Designed Outdoor Units (ODUs)

VRF V Plus ODUs are specially designed using CFD analysis to ensure maximum air flow and minimum pressure drop. This robust design makes the system function efficiently even under high ambient conditions as well as under extremely low ambient conditions.

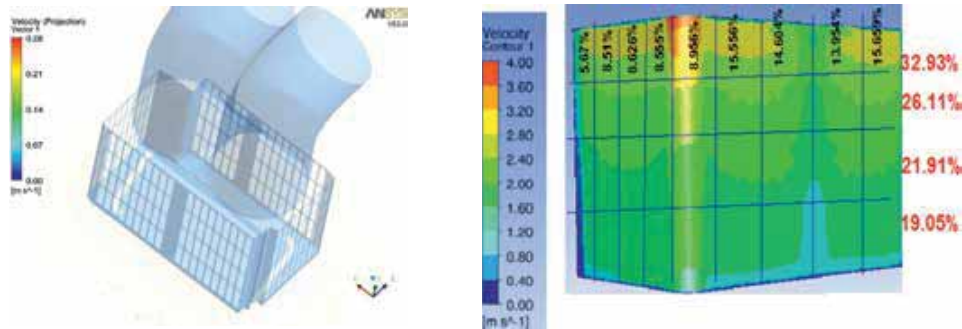

The condensers in these ODUs are precisely designed to ensure maximum efficiency of the VRF system. The specially designed condenser coil face area is at least 30% higher than in other systems.



The heat exchanger compartments are designed to ensure uniform air flow without any obstruction. This ensures efficient heat exchange and results in high efficiency. Specially designed louvre fins enhance the system efficiency by up to 7%.

The copper tubes are inner-grooved for high heat transfer. The condenser fans are fitted with high-efficiency DC motors that regulate air flow depending on demand resulting in power savings. The special design features incorporated in the VRF V Plus ODU result in:

- High COP and IPLV
- 100% capacity at 43°C
- Non-stop operation even at 56°C

Designed for High Ambient Conditions

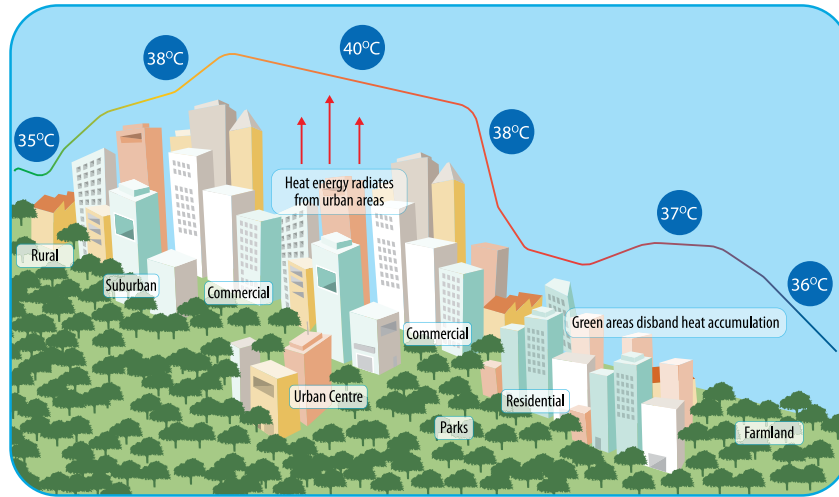

Urban Heat Effect

Most air conditioning systems are designed to deliver nominal capacity at 35°C. However, in a tropical country like India, ambient temperatures are much higher most of the time. The urban heat effect, whereby ambients are a couple of degrees higher than normal, makes the situation even more difficult.

Higher ambients result in system deration and higher power consumption as well. Blue Star's VRF V Plus is specially designed to deliver 100% capacity at a higher ambient of 43°C.

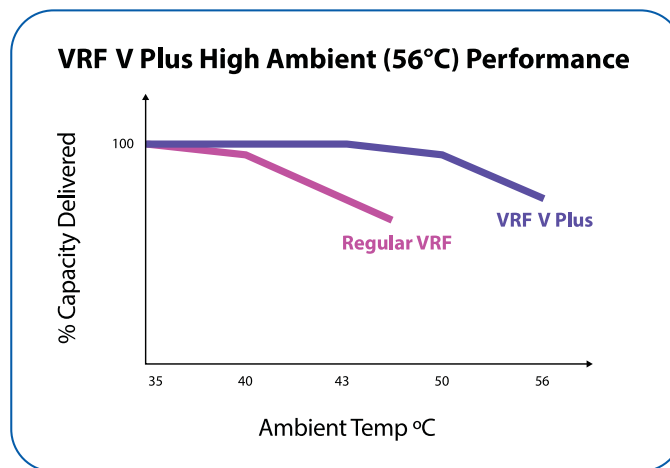

There are other reasons too why the Blue Star VRF V Plus operates more efficiently even under high ambient conditions:

- Enhanced coil face area up to 30% more than other VRF systems ensures that 100% capacity is delivered at 43°C
- This also ensures that the system is more efficient above 43°C

- Optimally selected compressors which do not unload till 48°C. As is known, when the ambient temperature goes higher than the ambient temperature that the system is designed for, inverter compressors in conventional systems will ramp up speed to meet load demands. However, there are limitations to this ramp-up beyond which the compressors unload. Hence, the deration of such systems is a summation of high ambient conditions as well as the drop in capacity due to compressor unloading.
- Advanced heat sink design and oil management systems ensure that the systems function non-stop till 56°C

Wide Operating Range

The VRF V Plus is designed with high pressure and low pressure protective systems enabling the machine to perform across a wide operating temperature bandwidth. The system can operate from 10°C to 56°C in the cooling mode and from -10°C to 24°C in the heating mode.

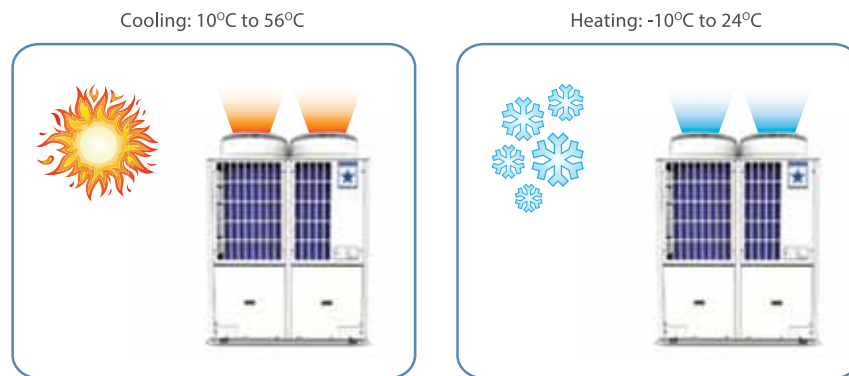

High System Efficiency

Enhanced coil face area, 100% inverter compressor advantage and system logic for compressor efficiency optimisation together result in superior performance of the entire system.

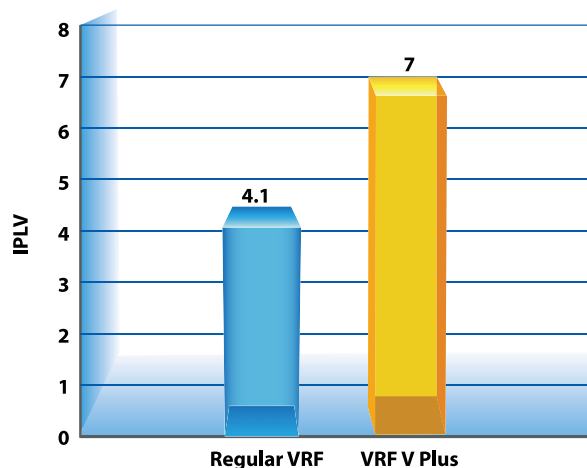

Superior Accumulator Design

The Blue Star VRF V Plus system is designed with the largest twin accumulator in its class. This new design allows the system to perform seamlessly in low-load conditions – even below 30% without tripping.



Diverse load handling ability

VRF systems are generally suggested for applications where there could be extreme variations in internal loads. However, the system design of the VRF system will decide the minimum operatable load conditions. Conventional VRF systems are not designed to operate below 30% of the load, the primary reason being the inability to manage the liquid refrigerant and oil in low load conditions. VRF V Plus is designed to handle load as low as 5%.

Long piping lengths

VRF systems generally need long refrigerant piping. And when pipe lengths are higher, refrigerant charge is proportionately higher. This calls for a better system design with proper accumulator sizing to handle the excess refrigerant during the functioning of the system. The Blue Star VRF V Plus is designed to operate efficiently even with very long piping lengths of up to 1Km.

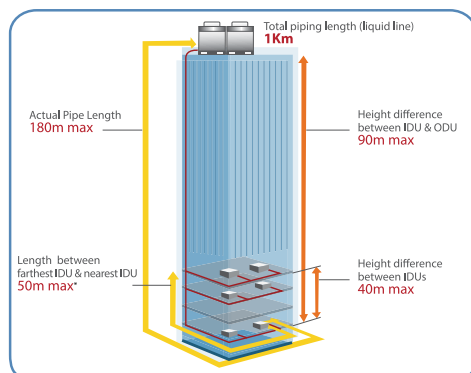

* Difference in length from first joint to the nearest & the farthest IDU's – 50m max. Length from first branch to the farthest IDU – 90m with modified pipe sizes

Increased reliability

If the excess liquid refrigerant is not handled effectively, it can enter the compressor and result in failure. Since the VRF V Plus uses the best accumulator design in the industry, it ensures that no liquid enters the compressor, thus increasing reliability.

Wide Voltage Range

With the alarming voltage fluctuations seen in most parts of India, most AC systems operate inefficiently or shut down. Blue Star VRF V Plus is designed to operate across a wide voltage range from 320 Volts to 460 Volts resulting in high uptime even in erratic power conditions.

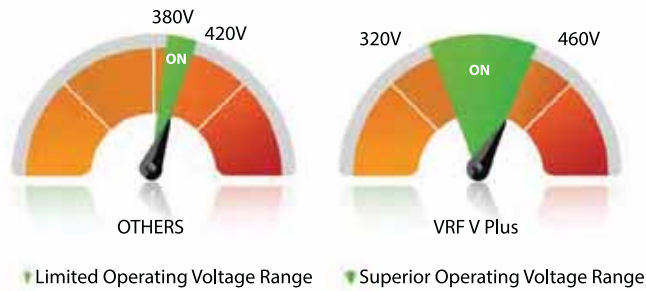

Innovative Refrigerant-cooled Heat Sink

Inverter drives play a very important role in regulating the capacity of the system based on load requirements. Keeping the inverter drive in a controlled temperature is very important for enhanced life, improved performance and reliability. The VRF V Plus is designed with an innovative refrigerant-cooled heat sink which helps maintain the drive within the allowable temperature range. This enhances the reliability of the system when it is working under very high ambient conditions.



Superior Oil Management System

Patented oil separator

Considering the very long piping lengths that the VRF V Plus must handle, it is crucial to have a superior oil management system to ensure reliability. The VRF V Plus has a specially designed and patented oil separator to ensure efficient oil recovery in the VRF System.

Oil swap

Oil is also swapped with the next ODU on a regular basis to maintain the oil balance in the system.

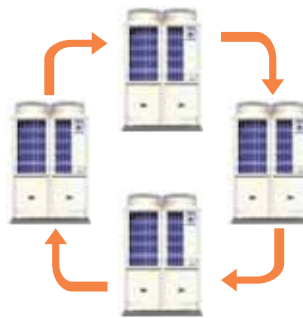

IDU oil return cycle

The cyclic oil recovery from the IDU is done by opening the electronic expansion valve wide and completely recovering the oil back to the ODU. Oil is recovered even from switched off indoor units.

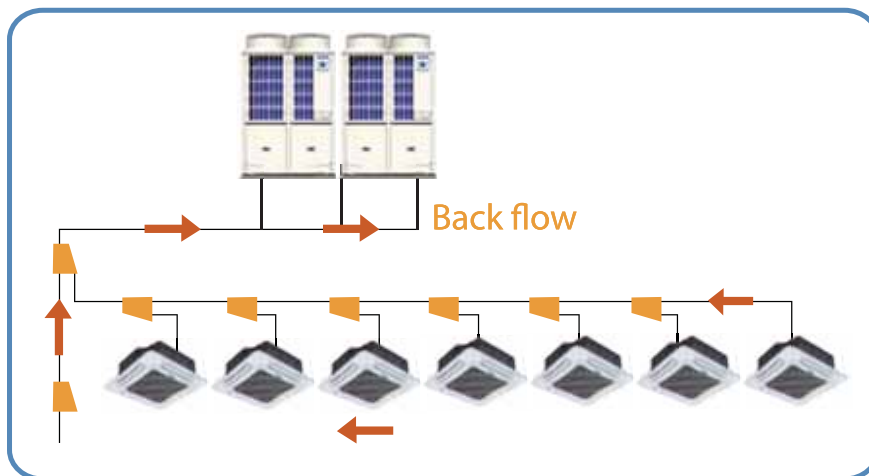

Service-friendly Design

All components of the outdoor unit are mounted in a separate compartment at the bottom and are accessible from all four sides. This makes these ODUs very easy to service.



Weather-proof ODU Design

The Blue Star VRF V Plus is specifically designed to handle extreme climatic conditions, corrosion and polluted atmosphere.

- Powder-coated GI sheet metal cabinets
- All hardware of anti-rust quality
- Conformal coating on PCBs to protect from dust and humidity
- Hydrophilic blue fin for better corrosion resistance
- Weather-proof enclosures for critical components

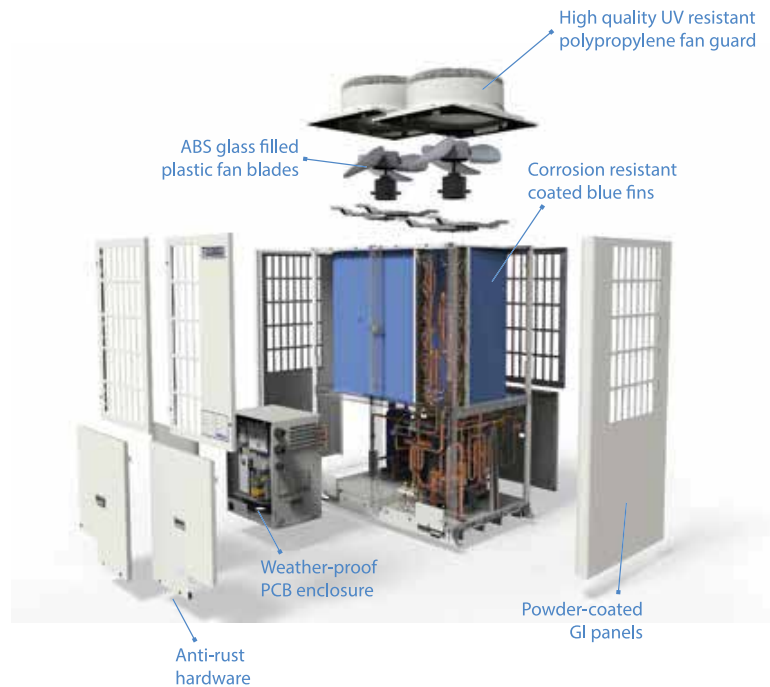

Conformal Coating for PCBs

All the PCBs in the VRF V Plus are coated with a special acrylic-based polymer film. This special conformal coat adheres to the norms of circuit board topology.

This special coating is used in various industries like automobile, defence, warehouse, space and marine applications. This protects PCBs from the harmful effects of the following:

Moisture | Heat | Fungus | Chemicals | Dust

This cover not only protects but also maintains the breathable layer of the PCB with good electrical properties. Besides, it is also eco-friendly.



Computerised Design for reliability

VRF systems fitted with inverter compressors run at various compressor speeds to regulate capacities to suit actual load requirements. These variations in speed cause vibrations to the copper pipe fittings. Hence, it is important to have a reliable and tested piping load design in the ODU. In the VRF V Plus, piping layers are created using Finite Element Analysis (FEA). This ensures reliability and trouble-free performance under various load conditions.

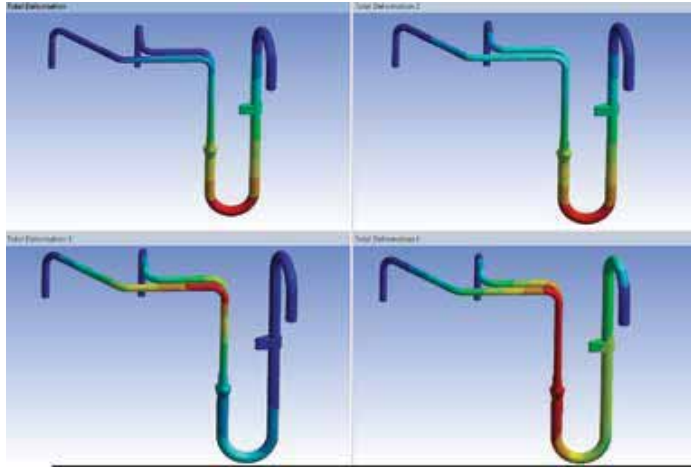

FEA images of ODU piping

Large Capacity and Wide Range of ODUs

The Blue Star VRF V Plus has a wide range of ODUs with capacities from 7HP to 28HP.



Up to 4 ODUs can be combined in one design to increase capacity up to a maximum of 112HP. From 7HP to 112HP, the Blue Star VRF V Plus offers you up to 72 combinations, the highest in the industry.



Long and Flexible Piping Design

The Blue Star VRF V Plus is designed with a large accumulator and an efficient oil recovery management system, hence allowing the system to be set up with long and flexible piping.

Total piping length	1km
Elevation between ODU and IDU	90m
Elevation between IDUs	40m
Elevation between ODUs	5m

Height Difference Between IDU & ODU - 90m Max

Actual Pipe Length - 180m Max

Height Difference between IDUs - 40m Max

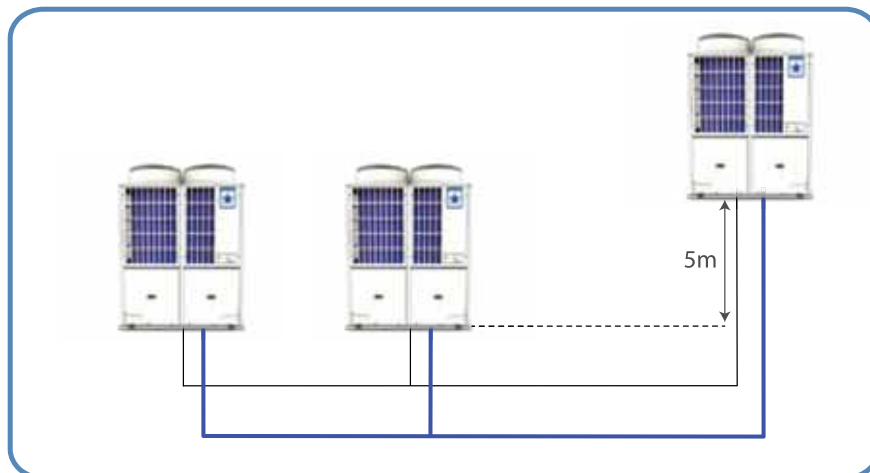
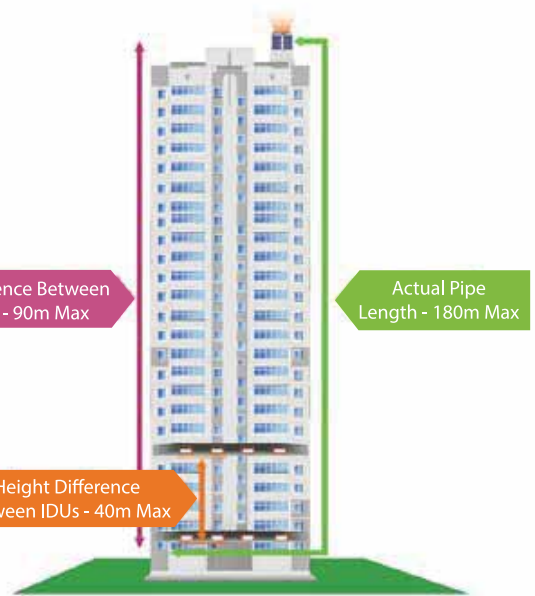

Quiet Mode

When the ambient noise levels are low, as at nights, noise levels of an operating AC can be disturbing especially in residential applications. To overcome this noise issue, the VRF V Plus has a unique 'Quiet Mode' feature which operates at two levels:

Quiet Mode: Outdoor fan speed is reduced.

Super Quiet Mode: Along with fan speed, compressor speed is also lowered. The start and end time of this feature can be set to suit each installation's requirements.



Demand Control Mode or Economy Mode

Under the Demand Control mode, the capacity of the ODUs of the VRF V Plus can be set at 25%, 50% or 75% depending on the need. This mode is very useful when sufficient DG power is not available to run the entire air conditioning system.

This feature can also be effectively used to optimise the usage of the VRF system during low demand periods.



Utilise AC for critical spaces

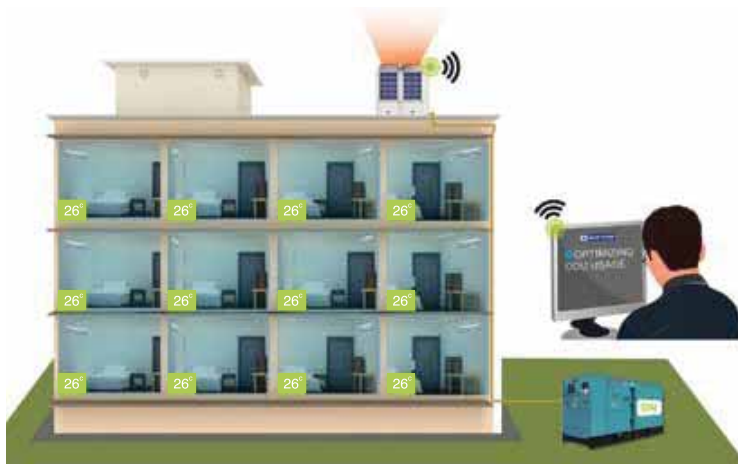

Uniform reduction of operating conditions

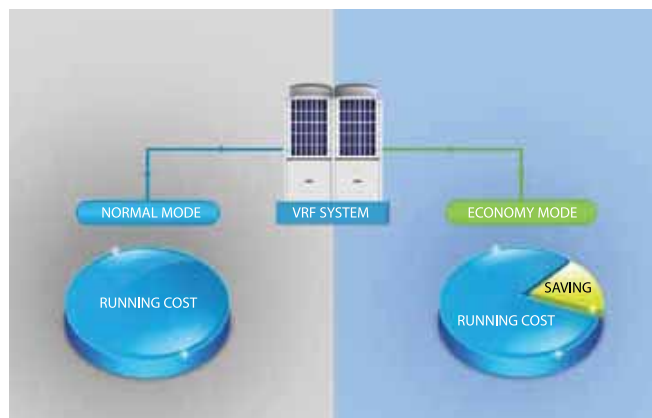

Optimised running cost

Emergency Backup Operation

Compressor backup

In ODUs that have two compressors, the VRF V Plus system can function even if there is a failure or maintenance downtime of one compressor.

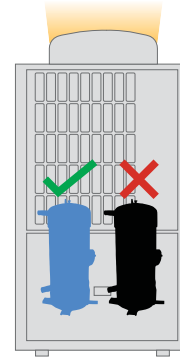

ODU backup

In a modular VRF V Plus design, where multiple units have been combined to run as one large unit, the system can operate even in case of a failure or a shutdown of one ODU. This feature helps ensure that cooling remains largely unaffected even during servicing or breakdown.

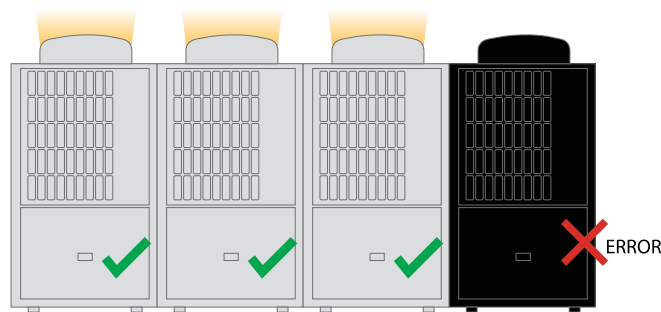

IDU emergency operation

All the IDUs in any VRF system are interconnected by the communication cables. In general, if there is a break in any communication cable, subsequent IDUs are affected and do not function. By activating the IDU emergency operation on the VRF V Plus, the other IDUs can function despite such a break.

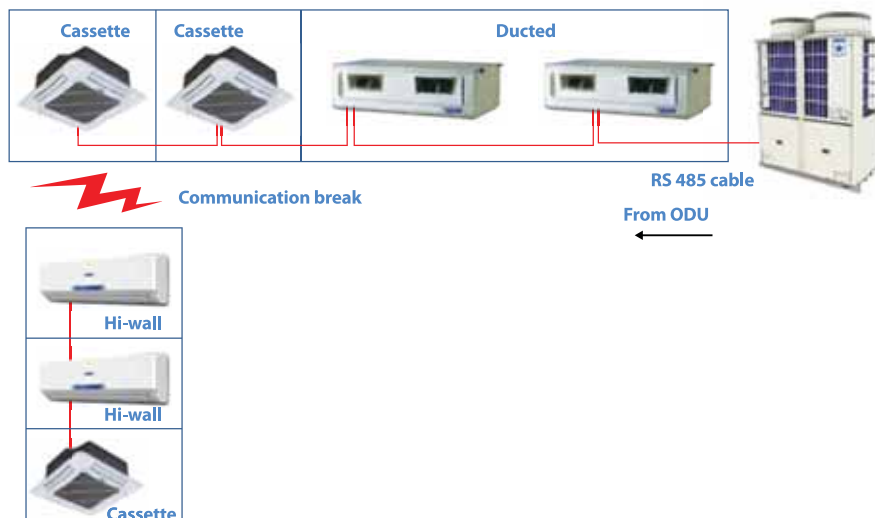

IDU isolation function

In the VRF V Plus, up to five IDUs can be switched to service backup mode even while the other indoor units in the same system run uninterruptedly. This feature is very useful while servicing a particular unit or units while not disturbing the overall system.



REGULAR VRF

VRF V Plus

Filter Clean Function

A 'filter clean' reminder function indicates the need to clean the filters. This can be reset after the filters are cleaned.



Blue Star's VRF V Plus offers you a wide choice of sophisticated and advanced controllers to suit various needs – from a simple cordless remote controller to highly advanced web-based controllers. There are also controllers available to calculate user-wise power consumption.

Cordless Remote Controller



Large LCD screen for clear display



Blue colour backlight for better clarity



Keys with symbols and description for user convenience



Real-time clock display



Room temperature indication



Display of various modes available ~ Cool mode, Heat mode, Fan mode, Dry mode



Fan speed adjustable to suit convenience of user



Inside room temperatures adjustable from 16°C to 30°C



Auto swing option for the louvres



5 options for positioning the louvres to suit the convenience of users



Preference mode:

- 2 settings to suit usage pattern
- Settings include various parameters like temperature, fan speed and louvre display
- When the preference mode key is pressed, the units function according to the preset conditions



Filter clean function

A 'filter clean' reminder function indicates the need to clean the filters. This can be reset after the filters are cleaned.



Timer function

The cordless remote controller enables the user to set on/off timings to switch the systems on or off at pre-determined times.



Key identification

Fluorescent keys enable easy identification of main keys even in the dark.



Flexible operation

The cordless remote controller has a unique feature that can communicate with the wired remote controllers. This is very useful when controlling units such as concealed splits and ductable split units which are mounted above the false ceiling.



Wired Controller

Highly advanced touch screen LCD, large size for clear display. Blue colour backlight for user convenience.



Filter clean reminder

A 'filter clean' reminder function indicates the need to clean the filters. This can be reset after the filters are cleaned.



Timer function

The remote controller enables the user to set on/off timings to switch the systems on or off at pre-determined times.



Flexible location

The wiring of this controller can be led either from the top or from the back allowing the flexibility to position the controller as required at different sites.



Self-diagnosis

These controllers are sophisticated and designed to display error codes to precisely identify the nature of certain problems.







Compatibility

These controllers are compatible with any type of IDU selected.



Group Controller

All the IDUs of the Blue Star VRF V Plus units are connected to corded or cordless remote controllers. For small office / retail units where the number of indoor units are not more than 16, the entire control can be from Group Controllers. These controllers have the following advantages:

-  Touch-screen based user-friendly controller
-  Up to 16 indoor units and 3 systems can be controlled
-  Parameters for individual indoor units can be set
-  Remote shielding of machines can be performed
-  Parameters like on/off status, mode of operation, temperature setting and fan speed can be viewed and set

When the number of IDUs is very high, it is useful to group the controllers into different categories and then segregate and control. For example, in hotels, all the rooms can be grouped under one category, all the banquet halls can be grouped under another category while the lobby could be a third category.

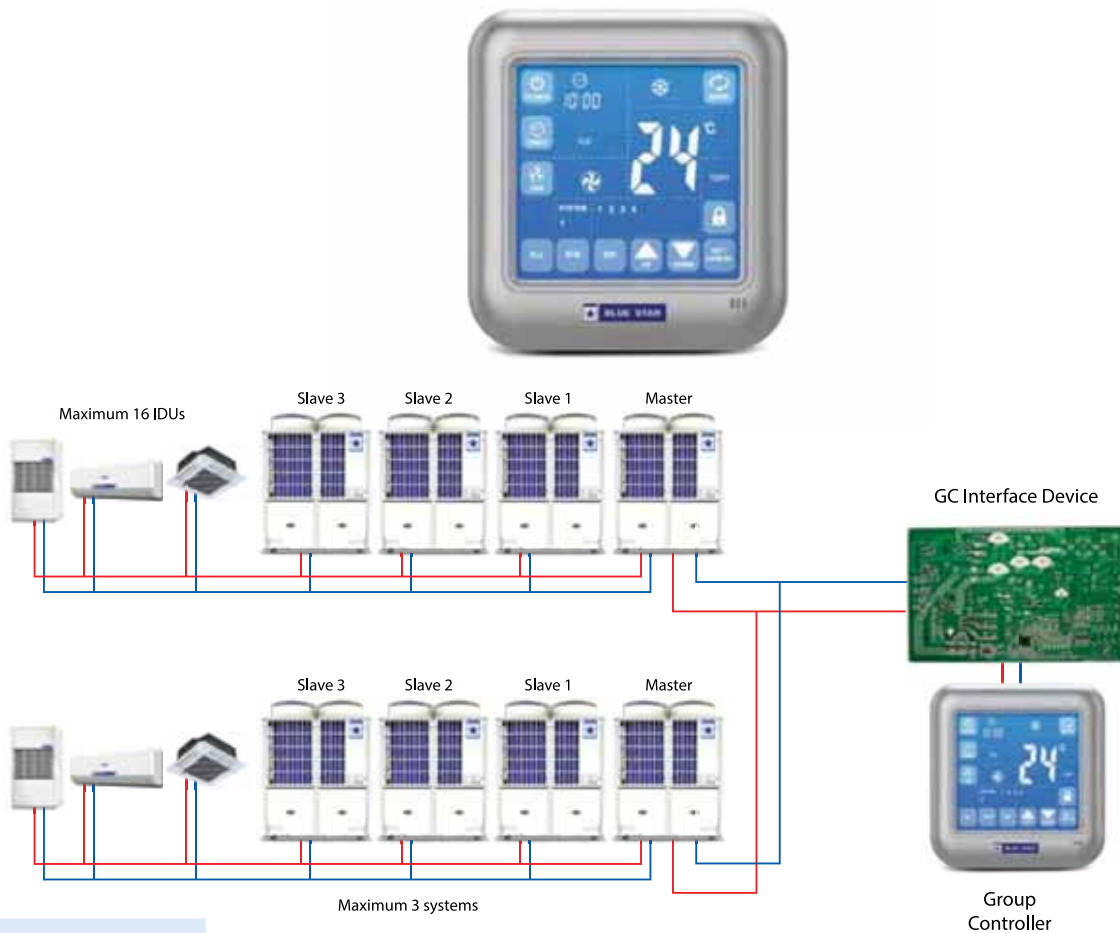

WiFi-based Central Controller

The WiFi based Central Controller of VRF V Plus enables the user to control multiple indoor units from a central location through an android or IOS based Tab or Smart Phone. It allows users to control

- 16 systems with 64 ODU's can be controlled
- Up to 992 indoor units can be individually controlled

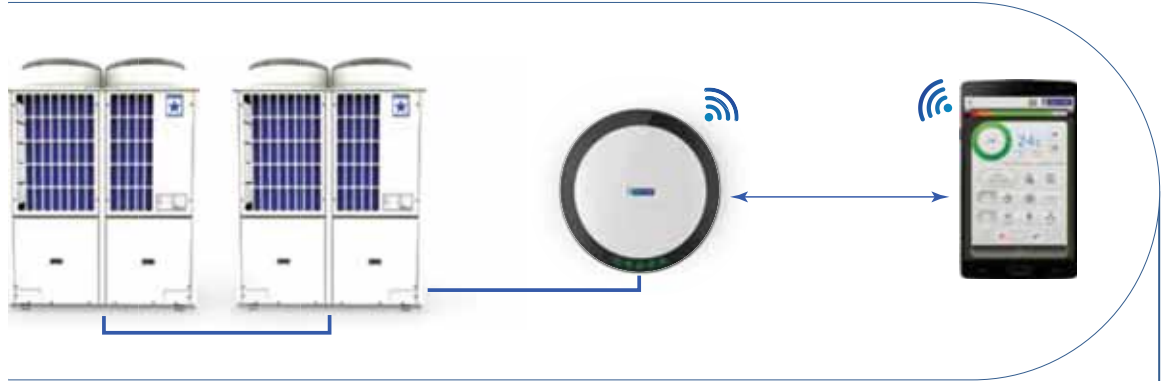

The WiFi interface is designed to be conveniently mounted on a wall or ceiling.

The outdoor unit can be located upto a maximum distance of 800 m and connected with RS485 communication wire to the WiFi interface device.





User's Choice of Control Device

VRF V Plus offers the user to choose between Android base and iOS base tab as control device. The user can monitor and control up to 992 Indoor Units from a single control device.



Multiple User Access

More than one user can be given access to control and monitor the system. User level access control for different functions can also be set for security purpose.



Scheduling

It gives convenience to programme the entire operational schedule on a weekly, monthly and yearly basis depending on the usage pattern and group-wise usage. Various functions like On/Off , Temperature , Fan speed etc can be time-scheduled as per the user's convenience. The entire system can be programmed group-wise/IDU-wise and be controlled through the central controller.



Master On/Off

This function enables the users to switch On/Off all IDUs/ODUs in one command.



Remote Shield Functioning

Allows the locking of adjustments of key parameters like On/Off mode, temperature and fan speed in each remote controller.



Flexibility

The control system has been designed to aid simple visual navigation which helps in managing different logical groups of IDUs so as to enable effective control over IDUs . Indoor units can also be grouped and group commands can be used for controlling a set of IDUs.

The same controller can be used as a debugger which helps diagnose and identify any problem in system by reading the displayed error codes.







Dynamic Display

The entire screen display is dynamic and is available in different colors to identify the status: Red - Faulty | Green - Functioning well | Orange - Functioning with Non-critical error



PC Monitoring System

The Blue Star VRF V Plus has an advanced PC monitoring system with the following features:

-  Up to 60 systems of 240 ODU's can be controlled and monitored
Up to 3720 IDU's can be controlled
-  Multiple groupings can be created for user convenience
-  Percentage of loading on each IDU can be displayed
-  Can be scheduled daily, weekly, monthly or annually
-  User-friendly navigation

System protection

The PC monitoring software offers the option of providing multiple usernames and multi-level passwords.



Keycard Controller



This feature is very useful for applications like hospitals, hotels and hostels. The on and off control of the IDUs can be connected with a keycard controller. The unit automatically functions based on the previous set status when the keycard is inserted and switches off when it is removed. This facility is available with most of the IDUs.



Fire Alarm System

All the IDUs and ODUs of the VRF V Plus have the provision to receive fire alarm signals. These signals can be given to any one of the IDUs or ODUs. Once the fire alarm signal is received, the entire system shuts down as a safety measure.

Remote Monitoring System









-  Monitor and control from anywhere in the world
-  System monitoring by Blue Star as an option
-  SMS and email for error intimation plus all the features of PC monitoring systems



Tenant Billing System

VRF systems are offered as solutions to various segments including commercial complexes where there are multiple users. When the builder/developer provides a common air conditioning facility, a tabulation of individual power consumption becomes difficult.

The Blue Star VRF V Plus comes with an advanced Tenant Billing Software which can capture the exact power consumption by each user, generate various reports, usage patterns and user-wise monthly bills.

-  Month-wise, indoor units-wise power consumption
-  Facility of extracting particular period data
-  Month-wise power charges for each indoor unit
-  Option of grouping tenants
-  Generation of reports on various parameters for each tenant
-  Provision of incorporating the electricity unit charges
-  Maintenance of database of each tenant
-  Tenant-wise generation of bills

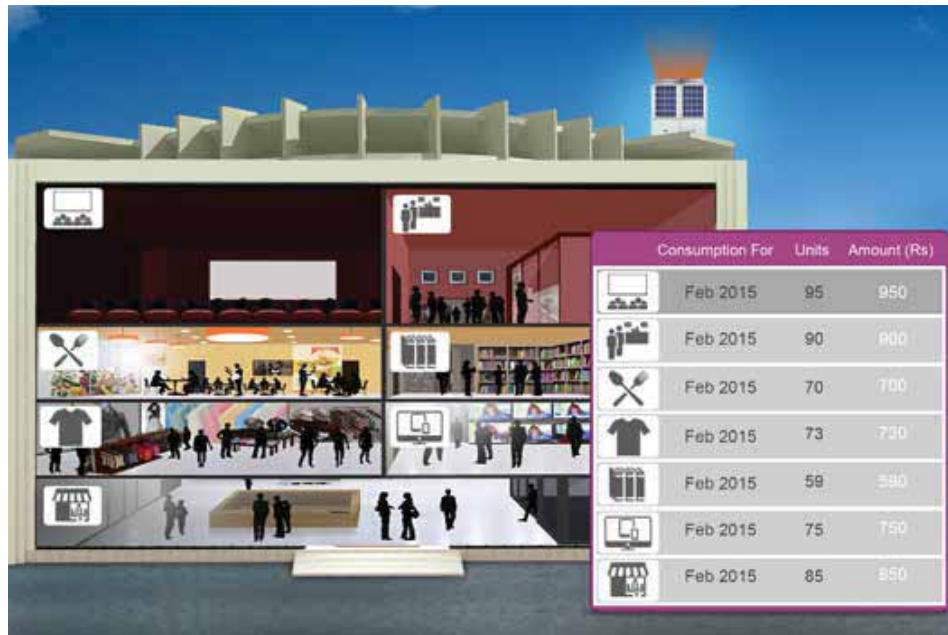

Mobile App

Blue Star's VRF V Plus systems are designed to operate using an advanced mobile app to enable the customer to view system status even from a remote location. The application designed for VRFs, works with internet-enabled smart phones and tablets. It is Android and iOS compatible. The entire system can be viewed in one screen. The unique features of the VRF app are:

°C Individual temperature setting for each IDU

☎ Through the mobile app, group or individual IDU control is possible on the following parameters:

- On/Off of the IDU
- Set temperature
- Mode of operation
- Fan speed selection
- IDU louvre adjustments
- Locking of the system



Remote Monitoring Service (RMS)

The Blue Star VRF V Plus is designed to operate through an advanced GPRS - based remote monitoring system, which is available as an option to all users.

The RMS has the following advantages:

-  Close monitoring of the site irrespective of the location
-  Automatic notification in the form of SMS or Email in case of any error
-  24x7 auto monitoring
-  Auto call login for service

The data captured and sent by RMS to the Central Service Team enables analysis by the local service team so as to be equipped with the necessary solutions to resolve any issue speedily.

This ensures:



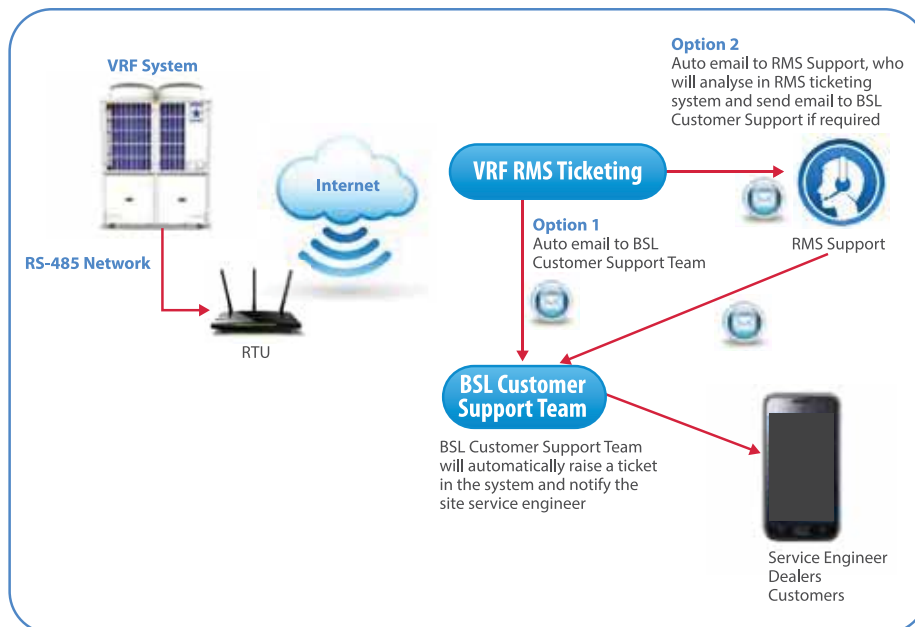
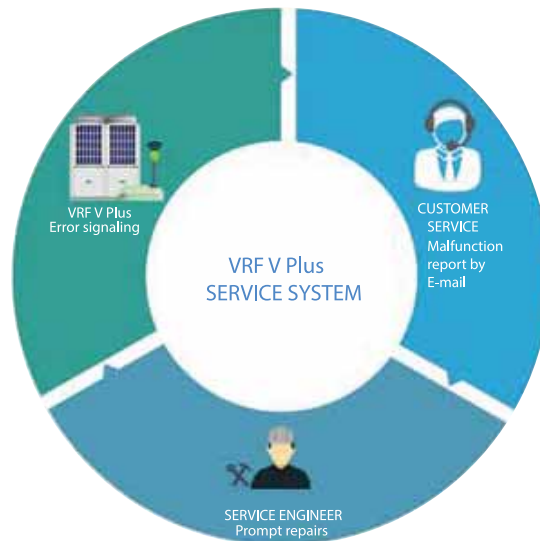

- Very quick response time
- Faster turnaround time
- Lower downtime of the system



BMS Compatibility

Blue Star VRF V Plus systems are highly compatible with advanced BMS systems. Each ODU has an RS-485 communication port through which it can be connected to the BMS through a Modbus converter. Besides, the VRF V Plus system is specially designed to enable the Modbus gateway to be directly connected through the RS-485 port of the Master ODU.

Some of the key features of the BMS module of VRF V Plus units are:

-  Up to 15 systems can be connected
-  A maximum of 62 IDUs in each system and 930 IDUs can be connected
-  Slave IDs for each IDU/ODU can be set
-  Debugger port is available
-  Options of converting to other protocols like Bacnet, Lonworks, etc., are available through additional converter



Data Concentrator

As we have seen so far, the Blue Star VRF V Plus is designed to operate with various advanced controllers. A data concentrator enables the customer to use more than one control system at a time. Using the data concentrator, up to a maximum of three interfaces can be connected simultaneously from the following controllers:

- PC monitoring
- Central controller
- Group controller
- BMS
- Tenant billing software
- Remote monitoring system
- Mobile app

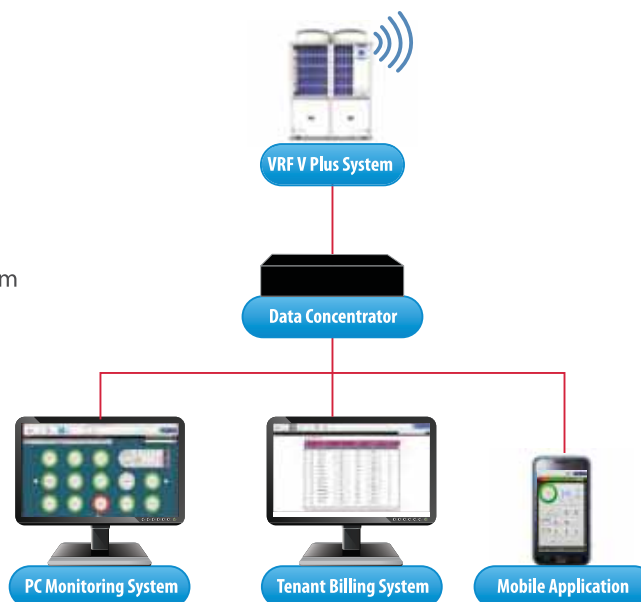

Hi-Wall Units



Capacities

0.8 TR, 1.0 TR, 1.3 TR, 1.5 TR, 1.7 TR and 2.0 TR

- Aesthetically superior with stylish design
- Very low noise, quiet operation
- Wide angle air flow to ensure even air distribution throughout the conditioned space



Multi-level Filtration

- Active Carbon Filter: Eliminates odour and deactivates harmful chemical gases
- Dust Filter: Picks dust particles from the air and maintains dust-free conditioned air
- Silver Ion Filter: Efficient in sterilising indoor air and reducing bacteria levels



Multi-fan Speed

Various levels of fan speed control are available to suit user comfort and convenience



Auto Restart

Automatic restart after power cut with all previously set parameters after power is restored



Filter Cleaning Reminder

Indicates when the filters need cleaning



Multi-mode Functions

Various modes can be selected depending on the usage pattern and the comfort levels required: • Auto • Cool • Heat • Dry • Sleep



Flexible Air Flow Patterns

Advanced louvres where the swing can be adjusted to meet the needs of air flow, ventilation and direction required

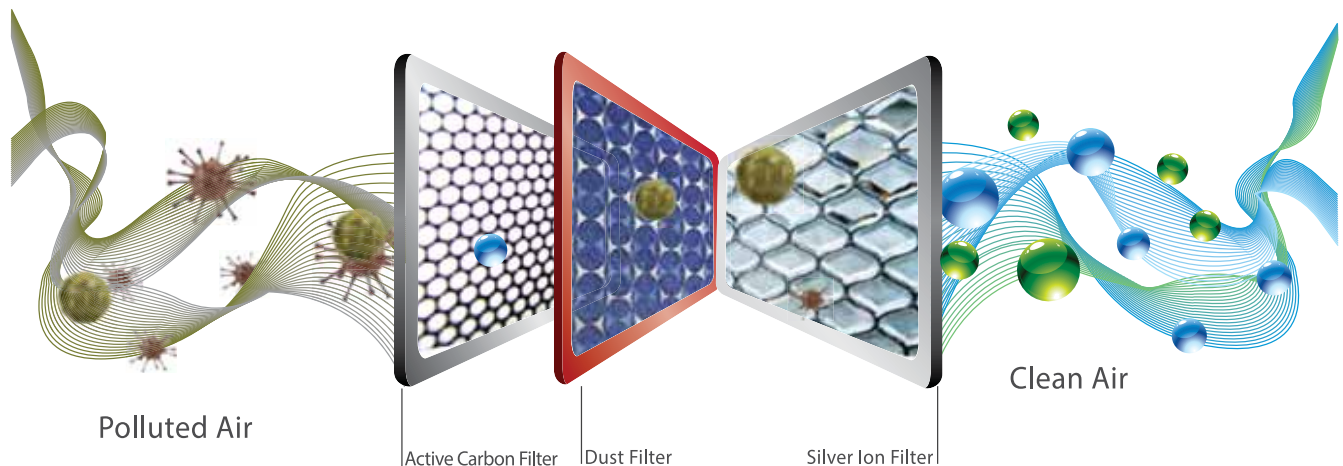



Capacities

1.0 TR, 1.3 TR, 1.5 TR, 1.7 TR, 2.0 TR, 2.3 TR, 2.8 TR, 3.2 TR, 4.0 TR and 5.0 TR



DC Inverter Motor

The advantage of having DC inverter motor is to provide the operation with step-less speed control and low noise



Wide Angle Air Flow

Wide angle air flow to ensure even air distribution throughout the conditioned space



Multi-mode Functions

Various modes can be selected depending on the usage pattern and the comfort levels required:

- Auto • Cool • Heat • Dry • Sleep



In-built Drain Pump

Powerful drain pump is provided to remove condensate drain water with a lift up to 1m. This helps for the installation of units even with deep ceiling beams



Fresh Air Provision

Provision to add fresh air helps maintain better indoor air quality



Filter Clean Reminder

Indicates when the filters need cleaning

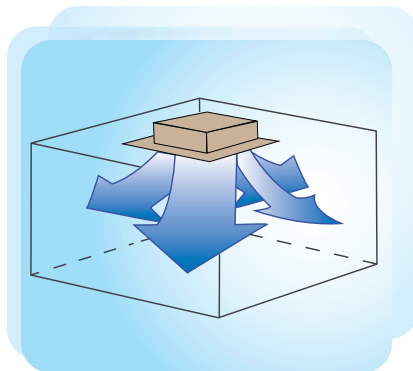
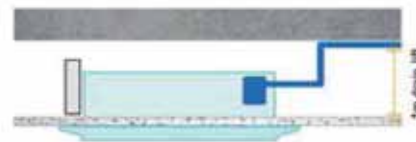

Four-way Airflow

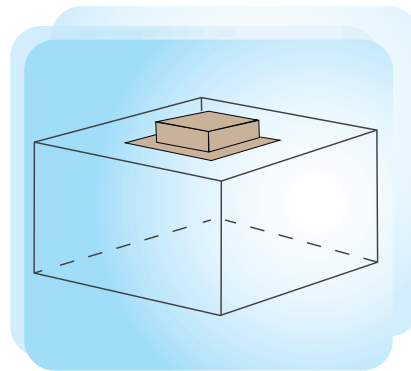

Saves Wall and Floor space

Compact Cassettes



Capacities

0.6 TR, 0.8 TR, 1.0 TR, 1.3 TR and 1.5 TR



Compact Design

650mm panel makes it very convenient to install in any grid type false ceiling; ideally suited for small cabins and conference rooms



DC Inverter Motor

The advantage of having DC inverter motor is to provide the operation with step-less speed control and low noise



Multi-mode Functions

Various modes can be selected depending on the usage pattern and the comfort levels required:

- Auto
- Cool
- Heat
- Dry
- Sleep



Filter Clean Reminder

Indicates when the filters need cleaning



Multiple Fan Speeds

Various levels of fan speed available to suit user comfort and convenience



In-built Drain Pump

Powerful drain pump is provided to remove condensate drain water with a lift up to 1m. This helps for the installation of units even with deep ceiling beams

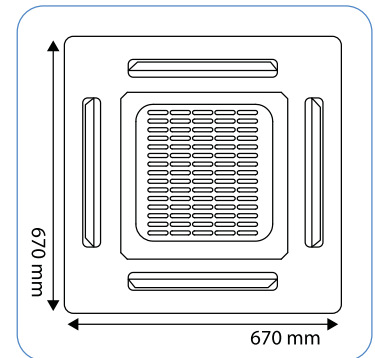

One-Way Cassettes



Capacities

0.6 TR, 0.8 TR, 1.0 TR, 1.3 TR and 1.6 TR



Ideal for Small Spaces

Ideally suited for small cabins, passage areas, corners of conditioned areas, applications with narrow ceiling, lobbies and interior roofs



Compact Design

Compact and slim design with ultra slim body measuring a total height of only 153mm



In-built Drain Pump

Powerful drain pump removes condensate drain water with a lift up to 750mm



Fresh Air Provision

Provision to add fresh air helps maintain better indoor air quality (For 1.3 TR and 1.6 TR Models)



Filter Clean Reminder

Indicates when the filters need cleaning



Multi-mode Functions

Various modes can be selected depending on the usage pattern and the comfort levels required:

• Auto • Cool • Heat • Dry • Sleep



Service-friendly Design

User-friendly detachable grille



Wide Angle Air Flow

Wide angle air flow to ensure even air distribution throughout the conditioned space

Two-Way Cassettes



Capacities

0.6 TR, 0.8 TR, 1.0 TR, 1.3 TR, 1.5 TR, 1.7 TR and 2.0 TR



Ideal for Narrow Spaces

Ideally suited for long narrow passage areas, open offices, cabinets, meeting rooms, etc.



Stylish and Slim Design

Suits the decor and interiors of any space, and convenient for installation as well



Quiet Operation

Optimised for air flow to minimise noise levels, as low as 24 decibels making it one of the quietest units in the industry



Filter Clean Reminder

Indicates when the filters need cleaning



Multi-mode Functions

Various modes can be selected depending on the usage pattern and the comfort levels required:

- Auto
- Cool
- Heat
- Dry
- Sleep



Wide Angle Air Flow

Wide angle air flow to ensure even air distribution throughout the conditioned space



Multiple Fan Speeds

Various levels of fan speed available to suit user comfort and convenience



Auto Restart

Automatic restart after power cut with all previously set parameters after power is restored

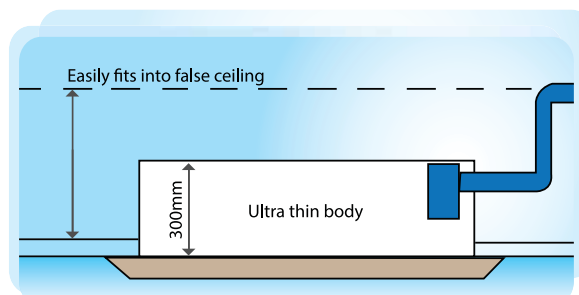



Floor Cum Ceiling Mounted Units



Capacities

1.0 TR, 2.0 TR, 3.0 TR, 4.0 TR and 5.0 TR



Convenient Positioning

Can be fixed either in the ceiling or the floor



Multi-mode Functions

Various modes can be selected depending on the usage pattern and the comfort levels required:

• Auto • Cool • Heat • Dry • Sleep



Multiple Fan Speeds

Various levels of fan speed available to suit user comfort and convenience



Filter Clean Reminder

Indicates when the filters need cleaning

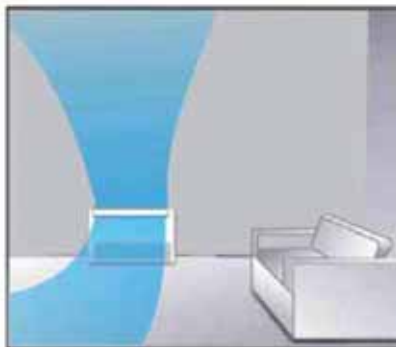

Floor mounted

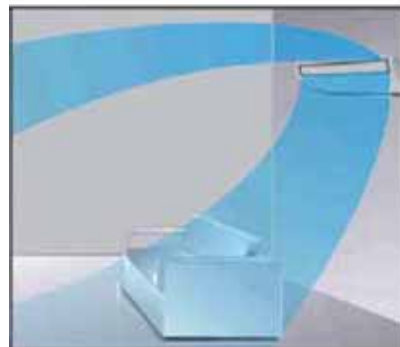

Ceiling mounted

Verticools



Capacities

2.0 TR, 2.3 TR, 2.8 TR, 3.2 TR and 4.0 TR



Ideal Where There is Ceiling Space Constraint

Ideally suited for large open halls and places where there is a limitation to use the ceiling space for mounting the indoor units



Filter Clean Reminder

Indicates when the filters need cleaning



Powerful Air Throw

Powerful blowers ensure air throw to cover maximum area



Flexible Air Flow Patterns

Advanced louvres where the swing can be adjusted to meet the needs of air flow, ventilation and direction required



Auto Restart

Automatic restart after power cut with all previously set parameters after power is restored



Verticool has powerful air throw to reach the farthest corners of the hall.



Concealed Splits



Capacities

0.8 TR, 1.0 TR, 1.3 TR, 1.5 TR and 2.0 TR



Ideal for Small Areas

Ideally suited for rooms in hotels, hospitals and any small area applications



Ultra Slim Construction

266mm height makes it very convenient to mount above false ceilings



Long Life

Powder coated for long life



Service-friendly Design

Detachable panel makes it easy for service



Variable Fan Speed

Various levels of fan speed available to suit user comfort and convenience



Quiet Operation

Mounting above a false ceiling reduces noise levels considerably

Ductable IDUs



Capacities

1.5 TR, 2.0 TR, 2.5 TR, 3.0 TR, 4.0 TR, 5.0 TR, 6.0 TR and 8.0 TR



Long Ducting

Ideal for applications where long lengths of ducting are possible and for better air distribution in the conditioned space



Higher Air Quantity

400 CFM per TR high air throw



Fresh Air

Designed with higher static to take care of fresh air requirements and long ducting lengths. Fresh air can be added as per quantities required by application.



Long Life

Powder coated for long life





Floor Mounted Packaged Units



Capacities

5.0 TR, 8.0 TR and 10.0 TR



Ideal for Large Spaces

Ideal for banquet halls and office areas where rooms are well defined



Higher Air Quantity

Floor mounted units have an advantage of higher air quantity



Fresh Air

Designed with higher static to take care of fresh air requirements. Required fresh air quantities can be added depending on application



Service-friendly Design

Since these units are mounted inside the room on the floor, they are easy to maintain



Long Life

The units are powder coated for long life

Heat Recovery Ventilation System



Energy Saving

Helps optimise the load due to fresh air by pre-cooling



Dual Function

The heat recovery units of Blue Star have both heat pipe and DX coil which can be connected with the VRF ODU. This helps maintain and regulate RH levels of the fresh air entering the conditioned space.

Treated Fresh Air Unit



Capacities

3.5 TR, 5.5 TR and 6.8 TR



Ideal for High Latent Load Applications

Ideal for requirements with large fresh air in high latent load applications like hotels, hospitals, auditoriums, etc.



Higher Air Quantity

TFAs have an advantage of higher air quantity



AHU Kits are specially designed to integrate AHUs with the ODUs of the Blue Star VRF V Plus system. There are many applications like banquet halls in hotels, operation theatres in hospitals and many special applications where there is a need to customise and provide AHUs. For these applications, it will not be viable to use the standard IDUs available in the VRF system.

Till the advent of the AHU Kit, VRFs were unable to cater to a complete facility due to the above limitations. With the introduction of the specially designed Blue Star AHU Kit, we can now connect customised AHUs to the VRF V Plus to suit various special needs and requirements.

AHUs of up to 32 TR with various combinations of static and CFM requirements can be connected to the VRF V Plus IDUs by using the AHU Kit.

Capacity (TR)	Model Code
5TR	DAEKIT-050
6.5TR	DAEKIT-065
8TR	DAEKIT-080
10TR	DAEKIT-100
12.5~15TR	DAEKIT-150
20TR	DAEKIT-200
25~32TR	DAEKIT-300



TECHNICAL SPECIFICATIONS - INDOOR UNITS

Hi-Wall Units



DESCRIPTION	UNITS	VHW-10	VHW-12	VHW-16	VHW-18	VHW-20	VHW-24
Cooling Capacity	TR	0.8	1.0	1.3	1.5	1.7	2.0
	kW	2.8	3.5	4.6	5.3	6.0	7.0
Heating Capacity	TR	0.9	1.1	1.4	1.7	1.9	2.2
	kW	3.1	3.9	5.0	5.8	6.6	7.7
Electrical Power Supply		230 Volts, 1 Φ , 50 Hz AC supply					
Air Flow (Hi/Mid/Lo/LL)	CFM	358/274/186/156	411/303/274/156	417/343/302/288	427/356/310/288	586/531/476/372	642/586/531/423
Sound Level	dB(A)	29	29	27	27	37	37
Fan Motor Input Power	W	45	45	58	58	72	72
Fan Motor Rated Current	A	0.25	0.25	0.31	0.31	0.4	0.4
Refrigerant Pipe Connections							
Liquid	mm	Φ 6.35	Φ 6.35	Φ 6.35	Φ 6.35	Φ 9.5	Φ 9.5
Gas	mm	Φ 9.5	Φ 9.5	Φ 12.7	Φ 12.7	Φ 15.9	Φ 15.9
Type of Connection		Flared					
Drain Pipe Dia.	mm	17.5	17.5	17.5	17.5	17.5	17.5
Dimensions (WxDxH)	mm	800x188x275	800x188x275	940x205x275	940x205x275	1045x235x315	1045x235x315
Net Weight	kg	7.5	7.5	10	10	12.5	12.5

Four-Way Cassettes

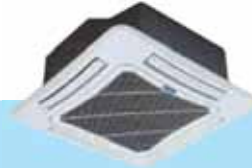

Model No.	UNITS	VLC-12	VLC-16	VLC-18	VLC-20	VLC-24	VLC-27	VLC-34	VLC-38	VLC-48	VLC-60A	
Cooling Capacity	TR	1	1.3	1.5	1.7	2	2.3	2.8	3.2	4	5	
	KW	3.5	4.6	5.3	6.0	7.0	8.1	9.8	11.3	14.1	17.6	
Heating Capacity	TR	1.1	1.4	1.7	1.9	2.2	2.5	3.1	3.5	4.4	5.5	
	KW	3.9	5.0	5.8	6.6	7.7	8.9	10.8	12.4	15.5	19.3	
Electrical Power Supply		230 Volts, Single Phase, 50 Hz AC Supply										
AIR FLOW (Hi/Mid/Lo)	CFM	470/415/355	470/415/355	490/445/385	650/560/475	695/590/530	695/590/530	945/825/710	1095/855/770	1095/855/770	1295/1120/915	
Sound Level (Lo)	dB (A)	36	36	36	37	38	38	40	41	43	47	
Fan Motor Input Power	Watts	48	48	48	59	59	59	98	98	98	120	
Fan Motor Rated Current	A	0.4	0.4	0.4	0.5	0.5	0.5	0.8	0.8	0.8	0.6	
Refrigerant Pipe Connections												
Liquid	mm	Φ 6.5				Φ 9.5						
Gas	mm	Φ 12.7				Φ 15.9						Φ 19.1
Type of Connections		Flared										
Drain Pipe Dia.	mm	25										
Net Dimensions (WxDxH) mm	Indoor Unit	840x840x190			840x840x240			840x840x320			910x910x293	
Net Weight (kg)	Grill	950x950x65	950x950x65	950x950x65	950x950x65	950x950x65	950x950x65	950x950x65	950x950x65	950x950x65	1040x1040x65	
	Indoor Unit	22.5	22.5	22.5	26.5	26.5	26.5	32.5	32.5	32.5	44.5	
	Grill	7	7	7	7	7	7	7	7	7	8.0	

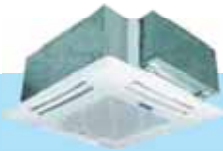

Compact Cassettes

Model No.	UNITS	VCC-08	VCC-10	VCC-12	VCC-16	VCC-18
Nominal Cooling Capacity	TR	0.6	0.8	1.0	1.3	1.5
	KW	2.1	2.9	3.5	4.7	5.3
Nominal Heating Capacity	TR	0.6	0.9	1.1	1.5	1.7
	KW	2.3	3.2	3.9	5.2	5.8
Electrical Power Supply		230Volts, Single Phase, 50Hz AC Supply				
AIR FLOW (Hi/Mid/Lo)	CFM	385/325/265	385/325/265	385/325/265	412/385/355	412/385/355
IDU Noise Level (Lo)	dB(A)	41.0	41.0	41.0	45.0	45.0
Fan Motor Input Power	W	35	35	35	35	35
Fan Motor Rated Current	A	0.4	0.4	0.4	0.4	0.4
Refrigerant Pipe Connections						
Liquid	mm			Φ 6.5		
Gas	mm			Φ 12.7		
Type of Connections				Flared		
Drain Pipe Dia.	mm			25		
Net Dimensions (WxDxH) (mm)	Indoor Unit	596x596x240	596x596x240	596x596x240	596x596x240	596x596x240
	Grill	670/670/50	670/670/50	670/670/50	670/670/50	670/670/50
NET WEIGHT (kg)	Indoor Unit	20.5	20.5	20.5	20.5	20.5
	Grill	3.5	3.5	3.5	3.5	3.5



One-Way Cassettes

DESCRIPTION	UNITS	VOC-08	VOC-10	VOC-12	VOC-16	VOC-19	VOC-24
Cooling Capacity	TR	0.6	0.8	1.0	1.3	1.6	2
	kW	2.2	2.8	3.5	4.6	5.6	7.1
Heating Capacity	TR	0.7	0.9	1.1	1.4	1.8	2.25
	kW	2.5	3.2	3.9	4.9	6.3	8
Electrical Power Supply		230 Volts, 1 Φ, 50 Hz AC supply					
Air Flow (Hi/Mid/Lo)	CFM	340/270/185	340/270/185	340/270/185	465/405/325	465/405/325	550/440/350
Sound Level	dB(A)	30	30	30	35	36	37
Fan Motor Input Power	W	29.5/26.7/25	31/27.2/25.3	31/27.2/25.3	39.5/33.5/25.6	41.5/36/28	56.2/40.2/28.7
Fan Motor Rated Current	A	0.24	0.25	0.25	0.27	0.32	0.36
Refrigerant Pipe Connections							
Liquid	Inch	Φ 6.35	Φ 6.35	Φ 6.35	Φ 12.7	Φ 12.7	12.7
Gas	Inch	Φ 12.7	Φ 12.7	Φ 12.7	Φ 15.9	Φ 15.9	15.9
Type of Connection		Flared					
Drain Pipe Dia.	mm	Φ 25	Φ 25	Φ 25	Φ 25	Φ 25	Φ 25
Dimensions (WxHxD) (Body)	mm	1054x153x425	1054x153x425	1054x153x425	1204x189x443	1204x189x443	1204x189x443
Dimensions (WxHxD) (Panel)	mm	1180x25x465	1180x25x465	1180x25x465	1350x25x505	1350x25x505	1350x25x505
Net Weight (Body)	kg	12.5	13	13	18.5	18.8	19.5
Net Weight (Panel)	kg	3.5	3.5	3.5	4	4	4

Two-Way Cassettes



DESCRIPTION	UNITS	VTC-08	VTC-10	VTC-12	VTC-16	VTC-18	VTC-20	VTC-24
Cooling Capacity	TR	0.6	0.8	1.0	1.3	1.5	1.7	2
	kW	2.2	2.8	3.6	4.5	5.3	6.0	7.0
Heating Capacity	TR	0.7	0.9	1.1	1.4	1.7	1.9	2.2
	kW	2.4	3.1	4.0	5.0	5.8	6.6	7.7
Electrical Power Supply		230 Volts, 1 Φ , 50 Hz AC supply						
Air Flow (Hi/Mid/Lo)	CFM	430/350/270	430/350/270	430/350/270	580/471/395	580/471/395	580/471/395	710/590/455
Sound Level	dB(A)	24	29	29	30	30	30	34
Fan Motor Input Power	W	67	67	67	128	128	128	162
Fan Motor Rated Current	A	0.45	0.45	0.45	0.55	0.55	0.55	0.75
Refrigerant Pipe Connections								
Liquid	Inch	Φ 6.35	Φ 6.35	Φ 6.35	Φ 9.5	Φ 9.5	Φ 9.5	Φ 9.5
Gas	Inch	Φ 12.7	Φ 12.7	Φ 12.7	Φ 15.9	Φ 15.9	Φ 15.9	Φ 15.9
Type of Connection		Flared						
Drain Pipe Dia.	mm	Φ 32	Φ 32	Φ 32	Φ 32	Φ 32	Φ 32	Φ 32
Dimensions (WxHxD) (Body)	mm	1,172x299x591	1,172x299x591	1,172x299x591	1,172x299x591	1,172x299x591	1,172x299x591	1,172x299x591
Dimensions (WxHxD) (Panel)	mm	1,430x53x680	1,430x53x680	1,430x53x680	1,430x53x680	1,430x53x680	1,430x53x680	1,430x53x680
Net Weight (Body)	kg	34	34	34	36	36	36	36
Net Weight (Panel)	kg	10.5	10.5	10.5	10.5	10.5	10.5	10.5

Floor Cum Ceiling Mounted Units



DESCRIPTION	UNITS	VFC-18	VFC-24	VFC-36	VFC-48	VFC-60
Cooling Capacity	TR	1.5	2.0	3.0	4.0	5.0
	kW	5.3	7.0	10.5	14.1	17.6
Heating Capacity	TR	1.7	2.2	3.3	4.4	5.5
	kW	5.8	7.7	11.6	15.5	19.3
Electrical Power Supply		230 Volts, 1 Φ , 50 Hz AC supply				
Air Flow (Hi/Mid/Lo)	CFM	765/618/530	825/710/590	1060/855/766	1355/1060/942	1355/1060/942
Sound Level	dB(A)	41	43	43	48	47
Fan Motor Input Power	W	125/105/85	125/105/85	148/131/122	242/208/190	242/208/190
Fan Motor Rated Current	A	0.65	0.65	0.78	0.98	0.98
Refrigerant Pipe Connections						
Liquid	mm	Φ 9.5	Φ 9.5	Φ 9.5	Φ 9.5	Φ 9.5
Gas	mm	Φ 12.7	Φ 15.9	Φ 19.1	Φ 19.1	Φ 19.1
Type of Connection		Flared				
Drain Pipe Dia.	mm	25	25	25	25	25
Dimensions (WxDxH)	mm	1068x675x235	1068x675x235	1285x675x235	1650x675x235	1650x675x235
Net Weight	kg	24	24	29	36.5	39

* Dimensions for ceiling mounted option. For floor mounted option, D and H will be interchanged.



Verticools

DESCRIPTION	UNITS	VVC-24	VVC-27	VVC-34	VVC-38	VVC-48
Cooling Capacity	TR	2.0	2.3	2.8	3.2	4.0
	kW	7	8.1	9.8	11.3	14.1
Heating Capacity	TR	2.2	2.5	2.9	3.5	4.4
	kW	7.7	8.8	10.2	12.4	15.5
Electrical Power Supply		230 Volts, 1 Φ , 50 Hz AC supply				
Air Flow (Hi/Lo)	CFM	655/545	655/545	1060/880	1060/880	1060/880
Sound Level	dB(A)	44	44	51	51	51
Fan Motor Input Power	W	152/123	152/123	300/240	300/240	300/240
Fan Motor Rated Current	A	0.75	0.75	1.51	1.51	1.51
Refrigerant Pipe Connections						
Liquid	mm	Φ 9.5	Φ 9.5	Φ 9.5	Φ 9.5	Φ 9.5
Gas	mm	Φ 15.9	Φ 15.9	Φ 19.1	Φ 19.1	Φ 19.1
Type of Connection		Flared				
Drain Pipe Dia.	mm	17.8	17.8	17.8	17.8	17.8
Dimensions (WxDxH)	mm	500x260x1680	500x260x1680	540x379x1775	540x379x1775	540x379x1775
Net Weight	kg	32	32	49	49	49



Concealed Splits

DESCRIPTION	UNITS	DCS10	DCS12	DCS16	DCS18	DCS24
Cooling Capacity	TR	0.8	1.0	1.3	1.5	2.0
	kW	2.9	3.5	4.7	5.3	7.0
Heating Capacity	TR	0.9	1.1	1.4	1.7	2.2
	kW	3.2	3.8	5.1	5.7	7.6
Electrical Power Supply		230 Volts, 1 Φ , 50 Hz AC supply				
Air Flow	CFM	350	350	450	500	650
External Static Pressure	Pa	10 ~ 20	10 ~ 20	20 ~ 25	20 ~ 25	25 ~ 30
Fan Motor Input Power	W	62	62	62	62	75
Fan Motor Rated Current	A	0.32	0.32	0.32	0.32	0.38
Sound Level	dB(A)	44	45	44	45	46
Refrigerant Pipe Connections						
Liquid	mm	Φ 6.35	Φ 6.35	Φ 6.35	Φ 6.35	Φ 9.50
	Inch	Φ 1/4	Φ 1/4	Φ 1/4	Φ 1/4	Φ 3/8
Gas	mm	Φ 12.7	Φ 12.7	Φ 12.7	Φ 12.7	Φ 15.9
	Inch	Φ 1/2	Φ 1/2	Φ 1/2	Φ 1/2	Φ 5/8
Type of Connection		Flared				
Drain Connection (OD)	Inch	Φ 3/4	Φ 3/4	Φ 3/4	Φ 3/4	Φ 3/4
	mm	Φ 19.1	Φ 19.1	Φ 19.1	Φ 19.1	Φ 19.1
Dimensions (WxDxH)	mm	1090x520x266	1090x520x266	1090x520x266	1090x520x266	1090x520x266
Net Weight	kg	33	33	35	35	35

Ductable IDUs



DESCRIPTION	UNITS	DSD18	DSD24	DSD30	DSD36	DSD48	DSD60	DSD72	DSD96
Cooling Capacity	TR	1.5	2.0	2.5	3.0	4.0	5.0	6.0	8.0
	kW	5.3	7.0	8.8	10.5	14.1	17.6	21.1	28.1
Heating Capacity	TR	1.7	2.2	2.7	3.3	4.34	5.5	6.5	8.7
	kW	5.7	7.6	9.5	11.4	15.2	19.0	22.8	30.4
Electrical Power Supply		230 Volts, 1 Φ , 50 Hz AC supply							
Air Flow	CFM	600	800	1000	1200	1600	1800	2300	3100
External Static Pressure	Pa	25~50	25~50	25~70	25~70	40~80	50~100	50~120	50~120
Fan Motor Input Power	W	134	134	335	335	335	670	670	670
Fan Motor Rated Current	A	0.69	0.69	1.71	1.71	1.71	3.43	3.43	3.43
Sound Level	dB(A)	38	39	41	41	48	52	53	55
Refrigerant Pipe Connections									
Liquid	mm	Φ 6.35	Φ 9.5	Φ 9.5	Φ 9.5	Φ 9.5	Φ 9.5	Φ 9.5	Φ 9.5
	Inch	Φ 1/4	Φ 3/8	Φ 3/8	Φ 3/8	Φ 3/8	Φ 3/8	Φ 3/8	Φ 3/8
Gas	mm	Φ 12.7	Φ 15.9	Φ 15.9	Φ 15.9	Φ 15.9	Φ 19.1	Φ 19.1	Φ 22.2
	Inch	Φ 1/2	Φ 5/8	Φ 5/8	Φ 5/8	Φ 5/8	Φ 3/4	Φ 3/4	Φ 7/8
Type of Connection		Flared							
Drain Connection (OD)	Inch	Φ 3/4	Φ 3/4	Φ 3/4	Φ 3/4	Φ 3/4	Φ 3/4	Φ 3/4	Φ 3/4
	mm	Φ 19.1	Φ 19.1	Φ 19.1	Φ 19.1	Φ 19.1	Φ 19.1	Φ 19.1	Φ 19.1
Dimensions (WxDxH)	mm	1000x600x265	1000x600x265	1000x700x318	1000x700x318	1320x800x310	1320x900x387	1320x900x387	1508x647x538
Net Weight	kg	28	32	45	45	56	86	87	90

Floor Mounted Packaged Units



DESCRIPTION	UNITS	DFM60	DFM96	DFM120
Cooling Capacity	TR	5.0	8.0	10.0
	kW	17.6	28.1	35.2
Heating Capacity	TR	5.5	8.7	10.9
	kW	19.0	30.4	38.0
Electrical Power Supply		380 - 420 Volts, 3 Φ , 50 Hz AC supply		
Air Flow	CFM	2000	3200	4000
External Static Pressure	Pa	40	60	80
Fan Motor Input Power	W	560	1500	1700
Fan Motor Rated Current	A	1.0	2.4	2.7
Refrigerant Pipe Connections				
Liquid	mm	Φ 9.5	Φ 12.70	Φ 12.70
	Inch	Φ 3/8	Φ 1/2	Φ 1/2
Gas	mm	Φ 19.1	Φ 28.6	Φ 28.6
	Inch	Φ 3/4	Φ 1 1/8	Φ 1 1/8
Type of Connection		Braze		
Drain Connection (OD)	Inch	Φ 1 1/4	Φ 1 1/4	Φ 1 1/4
	mm	Φ 32	Φ 32	Φ 32
Dimensions (WxDxH)	mm	900X660X1700	1160X660X1700	1160X660X1700
Net Weight	kg	136	205	210



Heat Recovery Ventilation System

DESCRIPTION	UNITS	DHRV03	DHRV05	DHRV09
Cooling Capacity	TR	0.75	1.3	2.2
	kW	2.6	4.7	7.7
Heating Capacity	TR	0.8	1.5	2.4
	kW	2.8	5.1	8.4
Electrical Power Supply		230 Volts, 1 Φ , 50 Hz AC supply		
Air Flow	CFM	170	320	530
External Static Pressure	Pa	80	80	80
Fan Motor Input Power	W	170	207	350
Fan Motor Rated Current	A	0.8	1.0	1.7
Refrigerant Pipe Connections				
Liquid	mm	Φ 6.35	Φ 6.35	Φ 9.50
	Inch	Φ 1/4	Φ 1/4	Φ 3/8
Gas	mm	Φ 12.7	Φ 12.7	Φ 15.9
	Inch	Φ 1/2	Φ 1/2	Φ 5/8
Type of Connection		Flared		
Drain Connection (OD)	Inch	Φ 3/4	Φ 3/4	Φ 3/4
	mm	Φ 19.1	Φ 19.1	Φ 19.1
Dimensions (WxDxH)	mm	1025x1030x355	1175x1030x355	1420x1145x355



Treated Fresh Air Unit

DESCRIPTION	UNITS	DTFA42	DTFA66	DTFA82
Cooling Capacity	TR	3.5	5.5	6.8
	kW	12.3	19.3	24.0
Heating Capacity	TR	3.8	6	7.5
	kW	13.3	20.9	26.0
Electrical Power Supply		230 Volts, 1 Φ , 50 Hz AC supply		
Air Flow	CFM	500	800	1000
External Static Pressure	Pa	80	80	80
Fan Motor Input Power	W	245	245	366
Fan Motor Rated Current	A	1.2	1.3	1.9
Refrigerant Pipe Connections				
Liquid	mm	Φ 9.5	Φ 9.5	Φ 9.5
	Inch	Φ 3/8	Φ 3/8	Φ 3/8
Gas	mm	Φ 15.9	Φ 19.1	Φ 22.2
	Inch	Φ 5/8	Φ 3/4	Φ 7/8
Type of Connection		Flared		
Drain Connection (OD)	Inch	Φ 3/4	Φ 3/4	Φ 3/4
	mm	Φ 19.1	Φ 19.1	Φ 19.1
Dimensions (WxDxH)	mm	823x1056x390	963x1056x390	1163x1205x390
Net Weight	kg	55	67	88

Ceiling Mounted Ductable IDUs - AHU Type



DESCRIPTION	UNITS	VSD-132A	VSD-216A	VSD-240A
Cooling Capacity	TR	11	18	20
	kW	38.7	63.3	70.3
Heating Capacity	TR	11.7	19.6	21.7
	kW	41.0	68.4	76.0
Electrical Power Supply		230 Volts, Single phase, 50 Hz AC supply		
Air Flow	CFM	4400	6800	8800
External Static Pressure	Pa	60	80	80
Motor Quantity	No.	2	3	3
Motor Output Power	kW	0.37	0.37	0.75
Pipe Connections				
Liquid	mm	15.9	15.9	19.05
	Inch	5/8	5/8	3/4
Gas	mm	28.6	28.6	34.9
	Inch	1 1/8	1 1/8	1 3/8
Type of Connection		Braze		
Drain Connection (OD)	mm	32	32	32
	Inch	1-1/4"	1-1/4"	1-1/4"
Dimensions (WxDxH)	mm	1860x635x465	2035x1085x550	2135x1215x690
Net Weight	kg	103	147	217
AHU Kit Model (Max)		DAEKIT-100	DAEKIT-200	DAEKIT-200

Floor Mounted Units - AHU Type



DESCRIPTION	UNITS	VFM-216A	VFM-264A
Cooling Capacity	TR	18	22
	kW	63.3	77.4
Heating Capacity	TR	19.5	24
	kW	68.3	83.5
Electrical Power Supply		380-420 Volts, 3PH, 50 Hz	
Air Flow	CFM	7200	8800
External Static Pressure	Pa	120	120
Motor Output Power	WATTS	2238	3000
Pipe Connections - OD			
Liquid	mm	15.9	19.05
	Inch	5/8	3/4
Gas	mm	28.6	34.9
	Inch	1 1/8	1 3/8
Type of Connection		Braze	
Drain Connection (OD)	mm	32	32
	Inch	1-1/4"	1-1/4"
Dimensions (WxDxH)	mm	1500x835x1830	1500x930x1950
Net Weight	kg	265	330
AHU Kit Model (Max)		DAEKIT-200	DAEKIT-200

Outdoor Unit



DESCRIPTION	UNITS	IVRFB-7 TC/H	IVRFB-8 TC/H	IVRFB-10 TC/H	IVRFB-12 TC/H	IVRFB-14 TC/H	IVRFB-16 TC/H	IVRFB-18 TC/H	IVRFB-20 TC/H	IVRFB-22 TC/H	IVRFB-24 TCN/THN	IVRFB-26 TCN/THN	IVRFB-28 TCN/THN	
Actual Cooling Capacity At 43 °C	HP	7	8	10	12	14	16	18	20	22	24	26	28	
	TR	5.6	6.4	8	9.6	11.2	12.8	14.4	16.0	17.6	19.2	20.8	22.4	
	kW	19.7	22.5	28.1	33.8	39.4	45.0	50.6	56.3	61.9	67.5	73.1	78.8	
	Btu/hr	67200	76800	96000	144000	134400	153600	172800	192000	211200	230400	249600	268800	
Actual Heating Capacity	TR	6.2	7.0	8.8	10.6	12.2	14.1	15.7	17.6	19.4	21.1	22.9	24.6	
	kW	21.7	24.8	30.9	37.1	42.9	49.5	55.2	61.9	68.2	74.3	80.4	86.6	
	Btu/hr	74400	84000	105600	127200	146400	169200	188400	211200	232800	253440	274560	295680	
Operating Ambient Temp. Range														
Cooling Mode	°C	10 °C to 56 °C												
Heating Mode	°C	-10 °C to 24 °C												
Power Supply	380 - 420 Volts, 3 Φ, 50 Hz AC supply													
Refrigerant	R410A													
Ref. Precharge Quantity	kg	9.0	9.0	9.5	9.5	12.5	13	13.5	14	14	16	17	18	
Overall Dimensions														
Width	mm	978	978	978	978	1300	1300	1500	1500	1500	1450	1450	1450	
Depth	mm	800	800	800	800	800	800	800	800	800	800	800	800	
Height	mm	1950	1950	1950	1950	1950	1950	1950	1950	1950	1950	1950	1950	
Weight														
Net Weight(TC/TH)	kg	261/265	264/268	272/276	272/276	364/372	372/379	397/403	406/412	406/412	416/422	431/445	431/445	
Shipping Weight (apprx.) (TC/TH)	kg	274/278	277/281	285/289	285/289	383/391	391/398	418/424	426/433	426/433	438/444	453/467	453/467	
Sound Level	dB(A)	56	57	58	60	63	64	66	67	67	68	69	69	
Compressor Type	Hermetically sealed scroll DC inverter driven													
No. of Compressors	No.	1	1	1	1	2	2	2	2	2	2	2	2	
Ref. Pipe Connections														
Liquid	mm/in	Φ 9.5/ 3/8	Φ 9.5/ 3/8	Φ 9.5/ 3/8	Φ 12.7/ 1/2	Φ 12.7/ 1/2	Φ 12.7/ 1/2	Φ 15.9/ 5/8	Φ 15.9/ 5/8	Φ 15.9/ 5/8	Φ 15.9/ 5/8	Φ 19.05/ 3/4	Φ 19.05/ 3/4	
Gas	mm/in	Φ 19.05/ 3/4	Φ 19.05/ 3/4	Φ 22.2/ 3/4	Φ 28.6/ 1 1/8	Φ 28.6/ 1 1/8	Φ 28.6/ 1 1/8	Φ 28.6/ 1 1/8	Φ 28.6/ 1 1/8	Φ 28.6/ 1 1/8	Φ 28.6/ 1-1/8	Φ 34.9/ 1-3/8	Φ 34.9/ 1-3/8	
Oil	mm/in	Φ 6.35/ 1/4												
Air-Cooled Condenser														
Type	Tube fin type													
Fan Type	Axial flow													
No. of Fans	1						2							
Air Quantity	CFM	7000	7000	7000	7000	9000	10200	12300	12300	12300	12300	13800	13800	
Motor Type	Brushless DC type													
Quantity	No.	1						2						
Power supply	230 Volts, 1 Φ, 50 Hz AC supply													

Notes:

1. Actual cooling capacities delivered are based on the following conditions:
Indoor temperature: 27°CDB, 19°CWB; Outdoor temperature: **43°CDB**; Piping length: 10m, Height difference: 0m.

2. Actual heating capacities delivered are based on the following conditions:
Indoor temperature: 20°CDB; Outdoor temperature: 7°CDB, 6°CWB; Piping length: 10m, Height difference: 0m.

Specifications are subject to change due to continuous product improvement

* The given sound level data are based on the measurements taken in an anechoic chamber and the actual sound levels may vary depending on the environmental noise conditions.

Hi-Wall Units

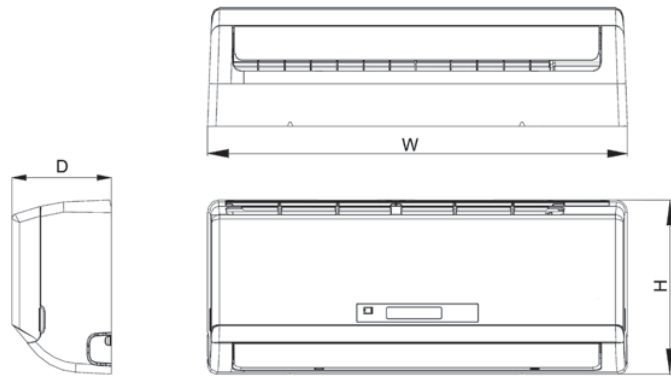

Model	W	D	H
VHW-10 / 12	800	188	275
VHW-16 / 18	940	205	275
VHW-20 / 24	1050	235	315

All dimensions in mm

Four-Way Cassettes

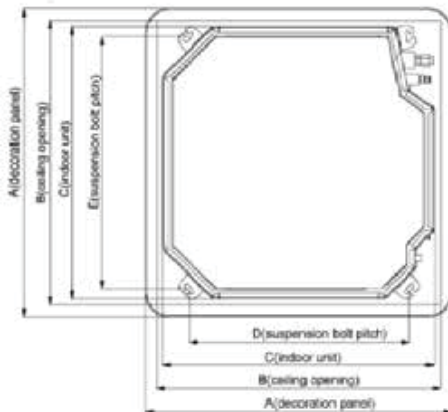
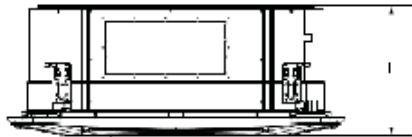

SR. NO.	MODELS	A(MM)	B(MM)	C(MM)	D(MM)	E(MM)	HEIGHT (H)	DRAINAGE PIPE OD(DIA)MM Ø25	OD OF CONNECTION PIPE(MM)	
									LIQUID PIPE	GAS PIPE
1	VLC-12,16,18	950	890	840	680	780	235	Ø25	Ø6.35	Ø12.7
2	VLC-20,24,27						285		Ø15.88	
3	VLC-34,38,48						365		Ø9.53	
4	VLC-60A						356		Ø19.05	

Compact Cassettes

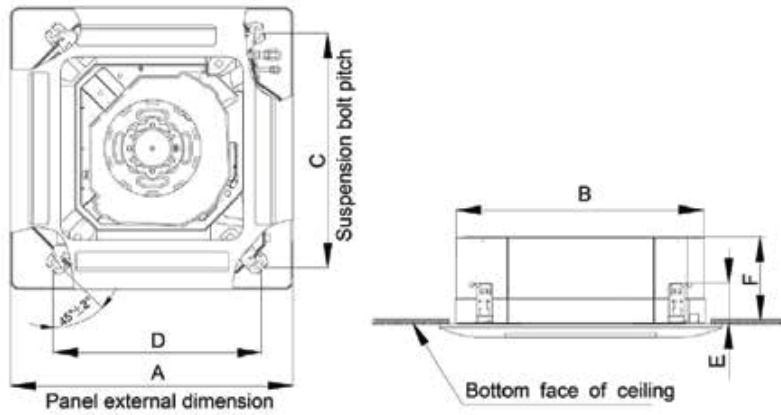

SR.NO	MODEL	A(MM)	B(MM)	C(MM)	D(MM)	E(MM)	F(MM)	DRAINAGE PIPE OD(DIA)MM	OD OF CONNECTION PIPE (MM)	
									LIQUID PIPE	GAS PIPE
1	VCC-08	670	596	592	571	145	240	Ø25	Ø6.35	Ø12.7
2	VCC-10									
3	VCC-12									
4	VCC-16									
5	VCC-18									

VOC - 08, VOC - 10, VOC - 12

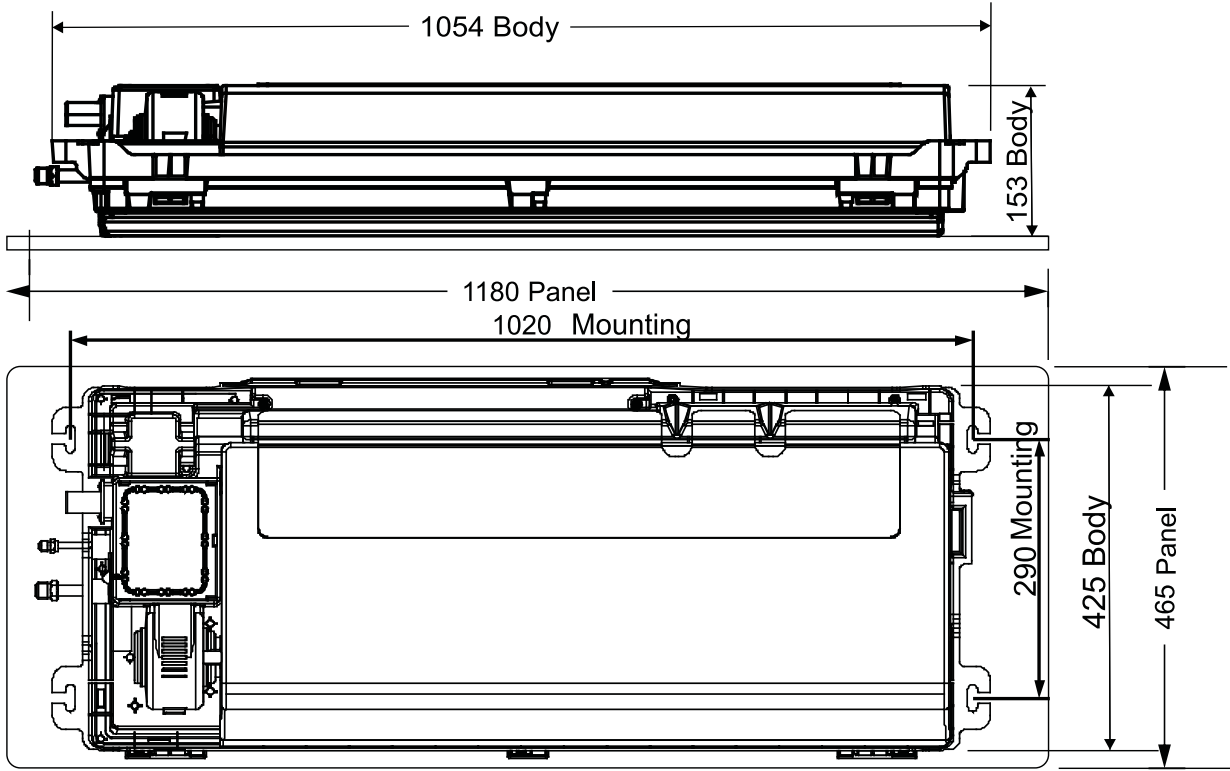

VOC - 16, VOC - 19, VOC - 24

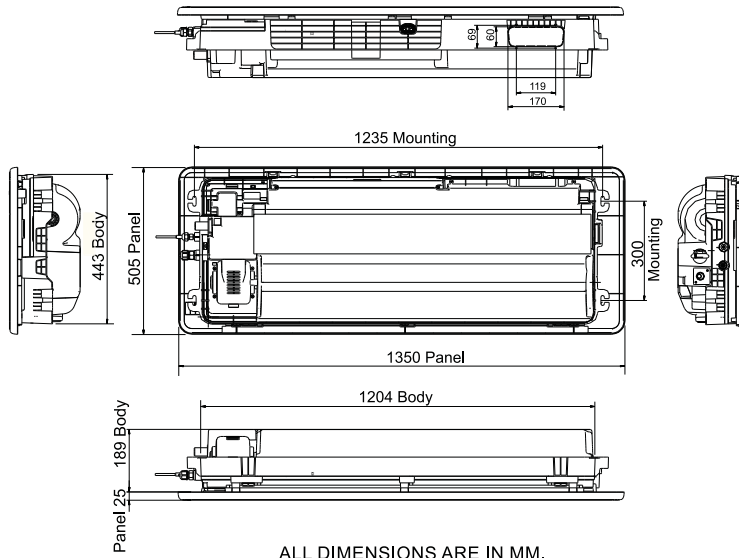

ALL DIMENSIONS ARE IN MM.

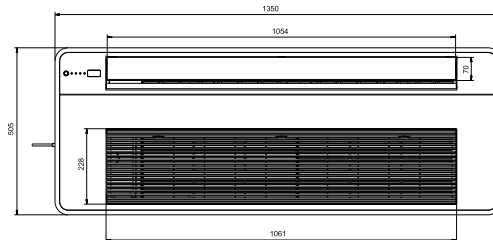

Two-Way Cassettes

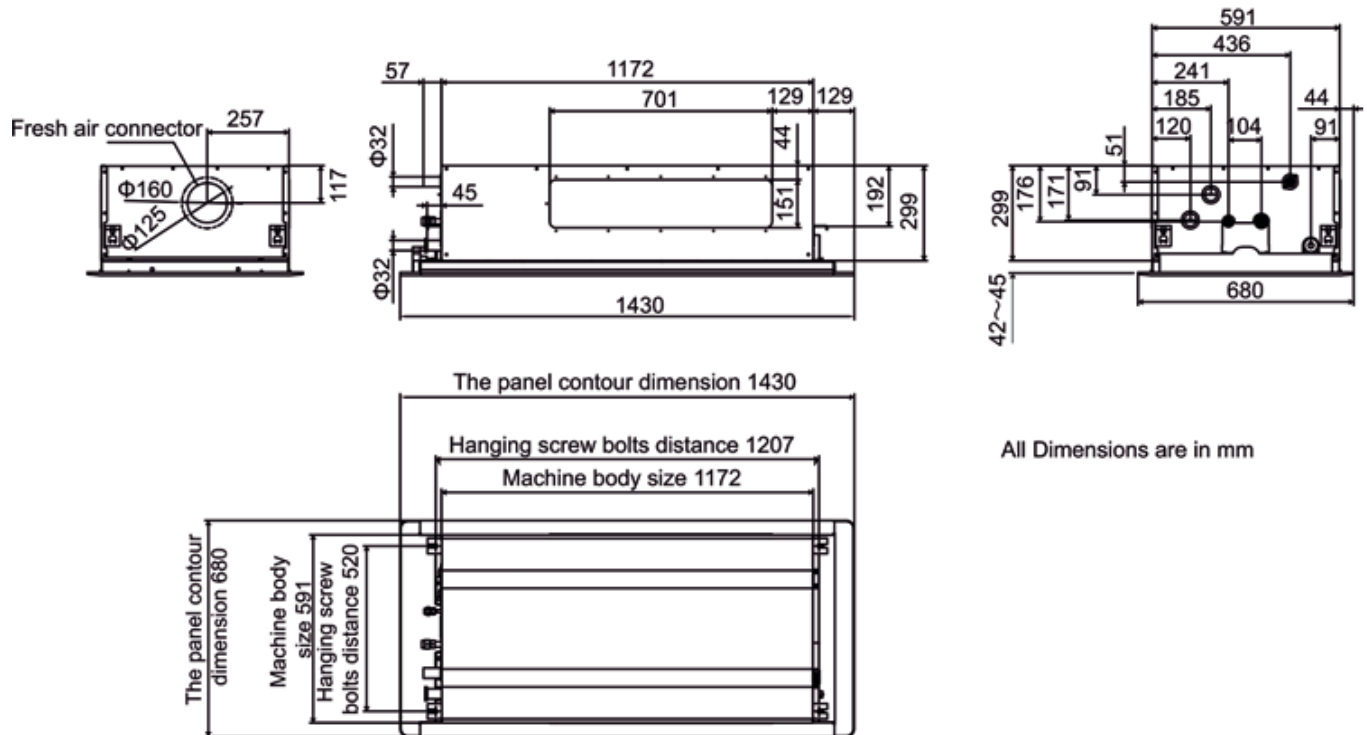

Floor Cum Ceiling Mounted Units

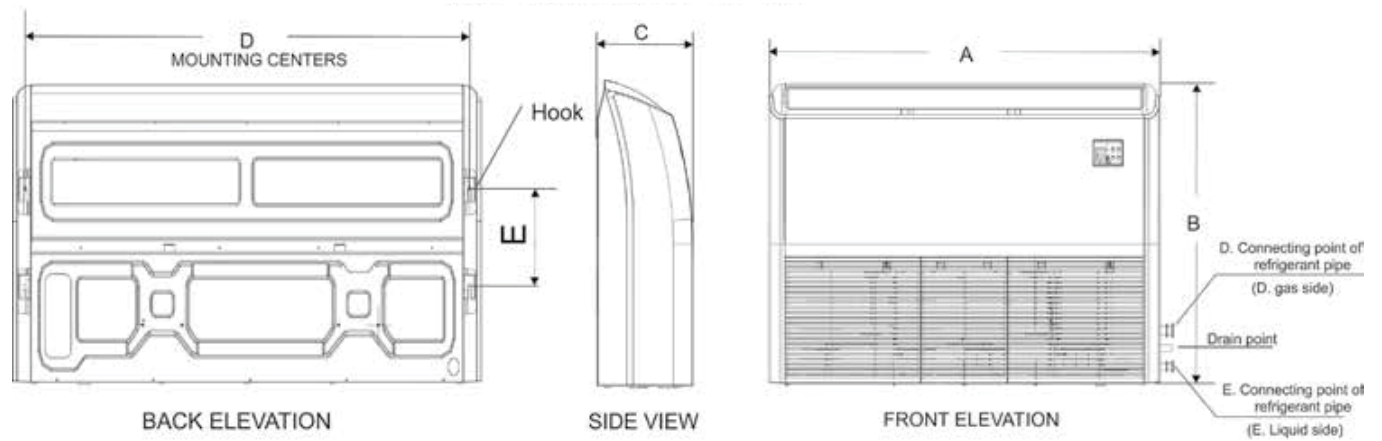

GA drawing for VFC models

Model	A	B	C	D	E
VFC - 18, VFC - 24	1068	675	235	983	220
VFC - 36	1285	675	235	1200	220
VFC - 48, VFC - 60	1650	675	235	1565	220

Verticools

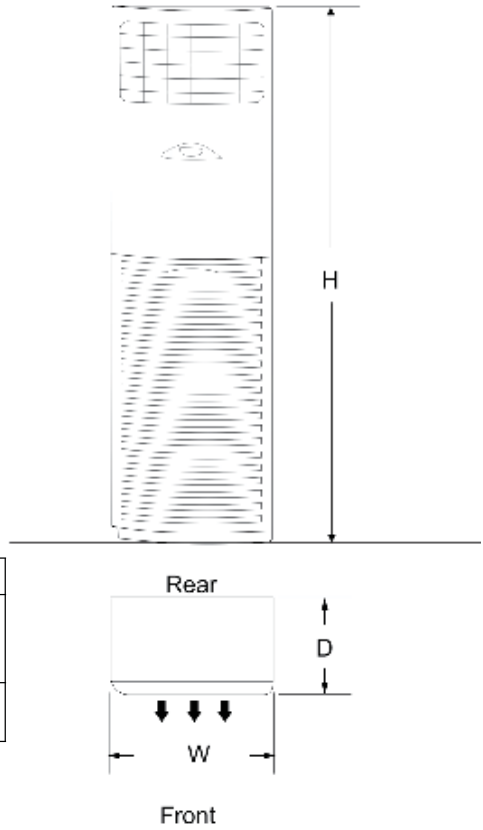

Model	H, mm	W, mm	D, mm
VVC - 24	1680	500	260
VVC - 27			
VVC - 34			
VVC - 38	1775	540	379
VVC - 48			

Concealed Splits

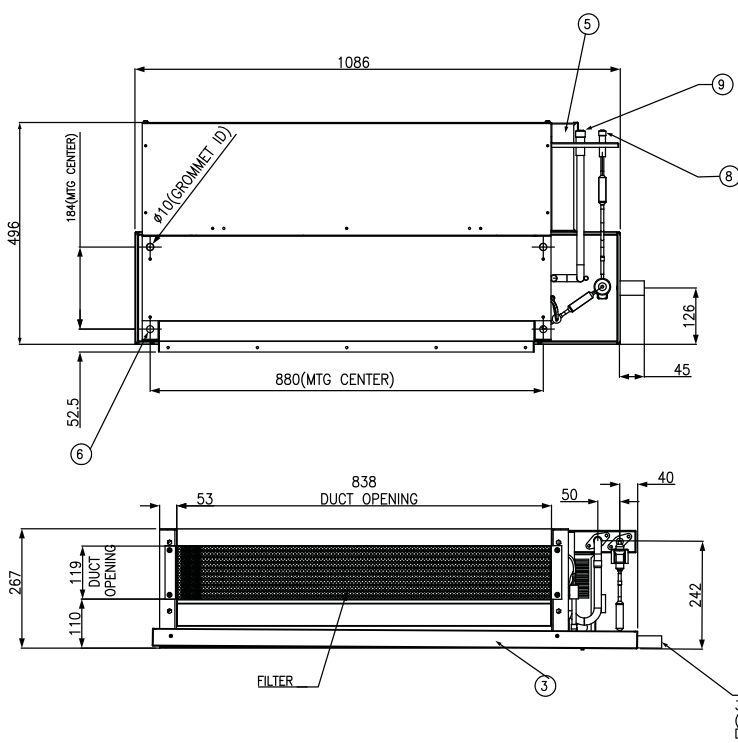

IDU CONNECTION			
SR.NO	MODELS	GAS	LIQUID
1	DCS10/12/16/18	1/2"	1/4"
2	DCS24	5/8"	3/8"

1	INDOOR COIL
2	FAN
3	DRAIN PAN
4	DRAIN CONNECTION ØAD
5	ELECTRICAL BOX
6	SUPPORT HOLES
7	AIR FILTER
8	LIQUID
9	GAS

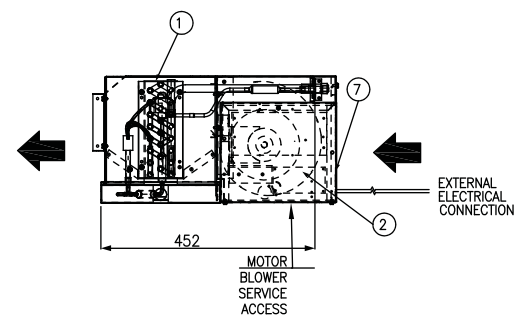

Floor Mounted Packaged Units

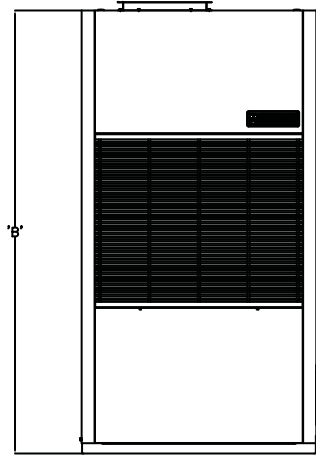
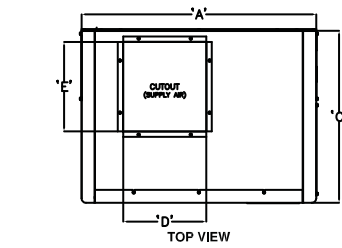

FRONT VIEW

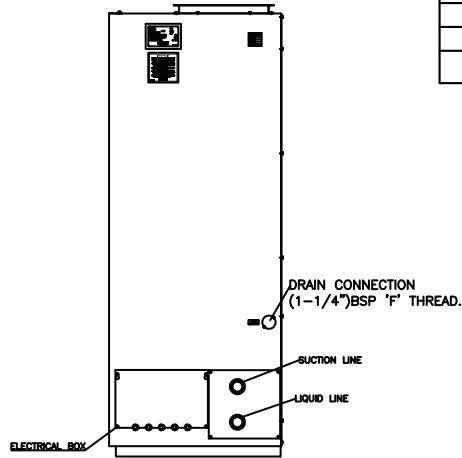

RIGHT HAND SIDE VIEW

MODEL	'A'	'B'	'C'	'D'	'E'
DFM-60	900	1700	660	318	343
DFM-96/120	1160	1700	660	399	343

IDU CONNECTION			
SR.NO	MODELS	GAS ϕ	LIQUID ϕ
1	DFM-60	3/4"	3/8"
2	DFM-96/120	1-1/8"	1/2"

NOTE
RECOMMENDED CLEARANCES
FOR PROPER MAINTAINANCE/SERVICE/
AIR CIRCULATION OF THE UNIT.

REAR TO WALL -910MM(3')MIN
FRONT TO WALL -910MM(3')MIN
TOP -1830MM(6')MIN
TOP WITH DUCT -1220MM(4')MIN

Heat Recovery Ventilation System

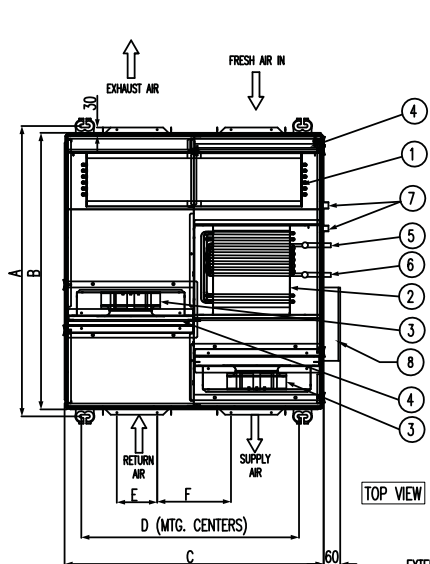

MODEL	A	B	C	D	E	F	G	H	I	J
DHRV 3	1065	1030	965	810	150	275	134	255	170	335
DHRV 5			1115	950		395	150		290	355
DHRV 9	1183	1145	1360	1130	250	390	177	350		385

S.N.	DESCRIPTION	QTY.
1	HEAT PIPE	1
2	DX COL WITH HEAT PIPE	1
3	BLOWER BACK WARD	2
4	FILTER	2
5	SUCTION CONNECTION	1
6	LIQUID CONNECTION	1
7	DRAIN CONNECTION (ALL 3/4" BSP MALE PIPE)	2
8	CONTROL BOX	1

CONNECTION DETAILS			
SR.NO	MODELS	SUCTION(ϕ)	LIQUID(ϕ)
1	DHRV-03	1/2"	1/4"
2	DHRV-05	1/2"	1/4"
3	DHRV-09	5/8"	3/8"

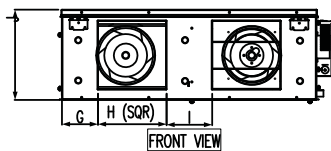

FRONT VIEW

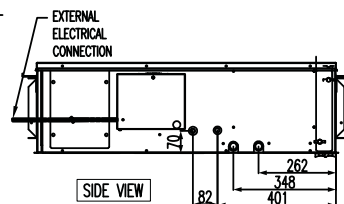

SIDE VIEW

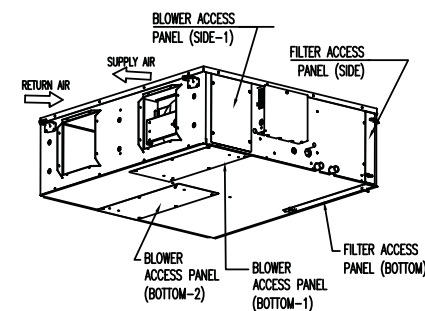
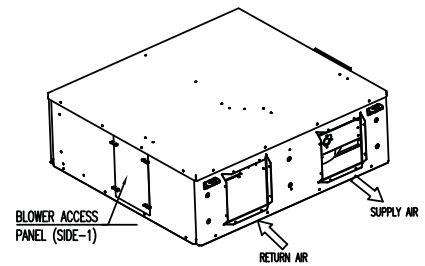

Outdoor Unit

14-16 HP

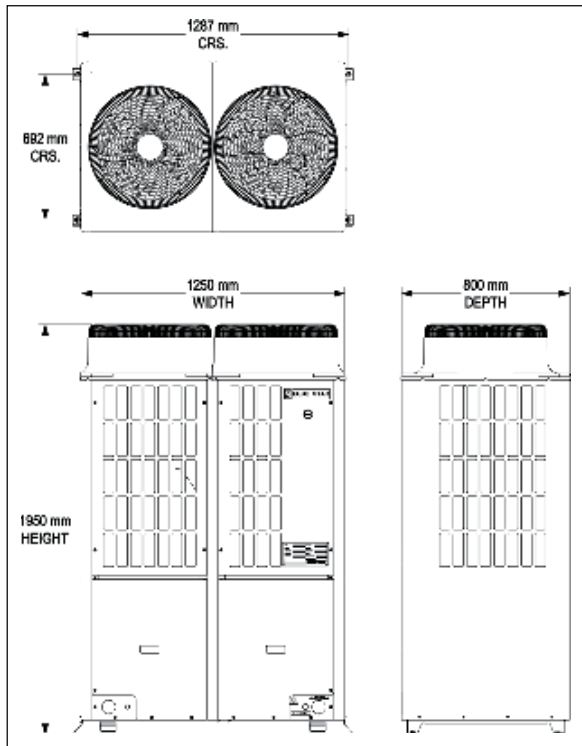

7-12 HP

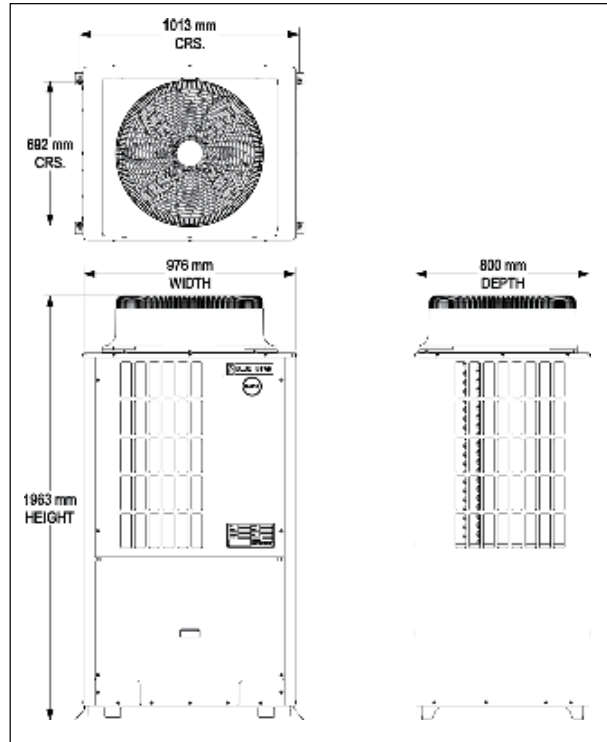

18-28 HP

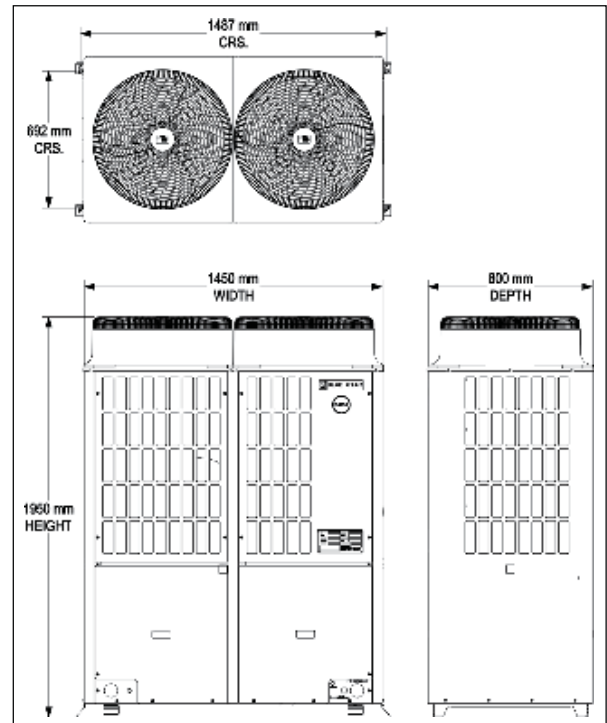



For more information, please contact **BLUE STAR LIMITED** **Ahmedabad:** 301 & 302, (3rd Floor), Abhishree Avenue, (Near) Nehru Circle, SM Road, Ambawadi, Ahmedabad - 380 015. Tel: (079) 40224000
Bengaluru: Anjuman KAY A R R Tower No - 28, Ward No 77, Mission Road, Bengaluru - 560027. Tel: (080) 41854000 **Bhubaneswar:** 3A, Satya Nagar, 2nd Floor, Bhubaneswar - 751 007. Tel: (0674) 2572403 / 2573670 **Chandigarh:** Adarsh Mall, 4th Floor, Plot No. 50, Industrial & Business Park, Phase - II, Chandigarh - 160 002. Tel: (0172) 5024000 **Chennai:** KRM Plaza, No 2, Harrington Road, Chetpet, Chennai - 600 031. Tel: (91) (44) 42444000 **Ghaziabad:** C 53A, Third Floor, Rajnagar District Center (RDC), Raj Nagar, Ghaziabad - 201001, Uttar Pradesh. Tel No: (0120) 2821400 **Goa:** 210, 2nd Floor, Gera's Imperium I, Pattoo, Panjim, Goa - 403 001. Tel: (0832) 2438171/2437287 **Gurgaon:** Vatika Atrium, 6th Floor, Golf Course Road, Sector 53, Gurugram - 122 002 (Haryana) Tel: (0124) 409 4000 **Guwahati:** Oasis Plaza, Dr. B. Baroah Road, Ulubari, Kamrup, Guwahati - 781007. Tel: (0361) 2468496 **Indore:** No. 502, Maloo-01, 26/C, Scheme No. 94/C Ring Road, Indore - 452 010 Tel: (0731) 4001211 / 4001311 **Jaipur:** A-19, 1st Floor, Main Sahakar Path, Near Sahakar Bhavan, Jaipur - 302 001. Tel (0141) 2744033-35 **Kochi:** 2nd Floor, Millennium Plaza, MKK Nair Road, Alinchuvadu Junction, Kochi - 682 024. Tel: (0484) 4499000 **Kolkata:** 7, Hare Street, Kolkata - 700 001. Tel: (033) 22134100 **Ludhiana:** SCO 16-17, Feroze Gandhi Market, Fortune Chambers, 3rd Floor, Ludhiana - 141001 (Punjab), Tel: 0161 5001404 **Lucknow:** 177/4, Faizabad Road, Lucknow - 226 007. Tel: (0522) 4034000 **Mumbai:** Blue Star House, 9-A, Ghatkopar Link Road, Saki Naka, Mumbai - 400 072. Tel: (022) 66684100 **Nagpur:** 219, Bajaj Nagar, 1st Floor, South Ambazari Road, Nagpur - 440 010. Tel: (0712) 2249000 / 6624000 **Pune:** 201/A, Nityanand Complex, 1st Floor, 247/A, Bund Garden Road, Pune - 411 001. Tel: (020) 41044000 / 26169332 **Raipur:** Alaska Corporates, 3rd Floor, Opp. VIP Road, Jivan Vihar Colony, G E Road, Raipur, Chhattisgarh - 492 006. Tel: (0771) 6544000 **Secunderabad:** Ashoka Raghupati Chambers, No 1-10-60 to 64, (4th Floor), S P Road, Begumpet, Hyderabad-500016 Telangana. Tel: (4044) 004000 **Thiruvananthapuram:** TC IV/962, 'Chandrika', Sree Chitra Nagar, PipeLine Road, Kawdiar, Thiruvananthapuram - 695 003. Tel: (0471) 2720025 / 65 **Vadodara:** Ramakrishna Chambers, 7th Floor, Productivity Road, Alkapuri, Vadodara - 390 007. Tel: (0265) 2330334 / 6614100 **Visakhapatnam:** D.No. 49-24-65/1, Near Sankarmatam Road, Madhura Nagar, Visakhapatnam -530 016. Tel: (0891) 2748405 / 2748433 **Vijayawada:** No. 40-1-62, Nagas Hafeez Plaza, Opposite to Grand Modern Super Market, Near BENZ Circle, MG Road, Vijayawada - 10 Tel: 0866 2484004
email: coolingsolutions@bluestarindia.com **Visit us at:** www.bluestarindia.com or SMS 'COOL' to 57575